

# WATER DISTRIBUTION OPERATOR I



**WATER-140**



ZERO  
TEXTBOOK  
COST

# Water Distribution Operator I

An Open Educational Resources Publication by College of the  
Canyons

Edited by Alexa Johnson & Kyra Karatsu

Version 1.5

2021



# Acknowledgements

College of the Canyons would like to extend appreciation to the following people and organizations for allowing this textbook to be created:

[California Community Colleges Chancellor's Office](#)

Chancellor Dianne G. Van Hook

[Santa Clarita Community College District](#)

[College of the Canyons Online Education](#)

© 2018, California Community Colleges, Chancellor's Office.

Except where otherwise noted, the content in this book is licensed under a [Creative Commons Attribution 4.0 International License](#).



# Table of Contents

CHAPTER 1 – INTRODUCTION TO WATER DISTRIBUTION	5
CHAPTER 2 – SOURCES AND CHARACTERISTICS OF WATER	20
CHAPTER 3 – REGULATIONS AND WATER QUALITY	31
CHAPTER 4 – SYSTEM DESIGN	51
CHAPTER 5 – WATER STORAGE	69
CHAPTER 6 – PIPELINES	80
CHAPTER 7 – VALVES	93
CHAPTER 8 – HYDRANTS	113
CHAPTER 9 – METER SERVICES	124
CHAPTER 10 – WELLS	139
GLOSSARY	152

# CHAPTER 1 – INTRODUCTION TO WATER DISTRIBUTION

This textbook is designed to provide the reader a general understanding of many of the drinking water distribution systems topics. It will also help prepare you for the California Certification Examinations. This chapter will introduce distribution systems and provide information related to becoming a certified operator and the associated regulations.

## OBJECTIVES

After reading this chapter, you should be able to:

- explain the general concept of water distribution;
- identify the topics of the other chapters within this textbook;
- state three main goals of a water professional;
- list the various certification levels of both distribution and treatment operators;
- discuss the criteria associated with becoming and working as a certified operator; and
- explain the content associated with taking a certification examination.

## Introduction to Water Distribution

A water distribution system is nothing more than a network of components designed to deliver water from a source to a user. It can be thought of as an array of piping networks and various pieces of equipment taking water from one location and delivering it to another.

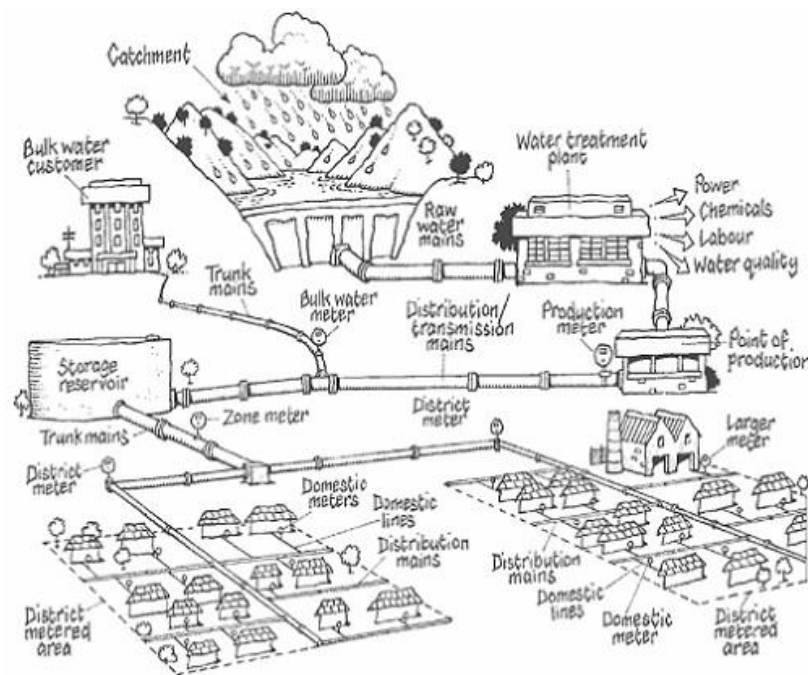

Figure 1.1: The urban water cycle<sup>1</sup>

<sup>1</sup> Image from [OpenLearn Create](#) is licensed under [CC BY-SA 2.0](#)

Many people put little thought into the water treatment and distribution processes. The same might be said with electricity. As long as water comes out of the faucet (tap) when you turn it on or lights turn on when you flip a switch, most people seem content and don't give the delivery process much thought. However, when the water stops flowing, customers take notice of their water service. Even then, the question is "Why is my water off?" and "When will it be back on?" There still isn't much thought put into the why? Very rarely are people interested in the process of water distribution when water service is uninterrupted. The complexities of getting water from its source to the "tap" often go unnoticed.

Drinking water originates from various places, but the largest amount of water on the planet can be found in the oceans. Approximately seventy percent (70%) of the surface of earth is covered by ocean. This corresponds to approximately ninety-six percent (96%) of all the water on earth. There is just one problem.



Figure 1.2: Ocean Water<sup>2</sup>

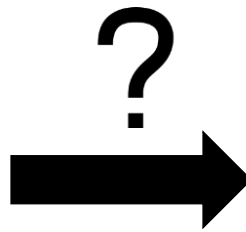

Figure 1.3: Drinking water<sup>3</sup>

Ocean water is salty and not suitable for human consumption. There is only a small portion of fresh water (not having salt) that is accessible for sustaining human life. This topic will be discussed in more detail in Chapter 2.

If "fresh" water is accessible from lakes and rivers or pumping groundwater to the surface, it needs to be transported to communities. A simple description of this process can be broken down into four simple terms, conveyance, treatment, distribution, and customer tap. This may seem like a relatively straightforward and easy process, but there are complexities to this system. These processes (except water treatment) will be discussed in detail in this text. This text is designed to cover these specific aspects of water distribution. They include:

- Operator Certification
- Sources of Supply
- Water Characteristics
- Water Quality and Regulatory Compliance
- Distribution System Design

<sup>2</sup> Photo by [Marianne Heino](#) on [Unsplash](#)

<sup>3</sup> Photo by [insightzaoya](#) is licensed under [CCO](#)

- Water Main Pipes
- Water Valves
- Fire Hydrants
- Water Meters and Services
- Pumping
- Water Wells
- Water Storage
- Cross Connection Control
- Safety

Water is essential to life. Therefore, water utility employees should always remember the following goals:

1. Provide a safe and potable water supply to the customer
2. Provide a reliable water supply to the customer
3. Provide this water supply at a reasonable cost with excellent service to the customer

If you haven't noticed, the common thread in each of these objectives is the "customer." It is important for water professionals to understand and realize they are providing a critical service to millions of people throughout the world. Having an understanding of these main objectives helps each employee put in to perspective the responsibility associated with being a water utility professional. We are providing a vital service to society.

Each chapter in this text will delve into various topics ranging from where our water originates and how it gets to our taps in a safe, reliable, and cost effective manner. It will focus on the distribution of potable drinking water and the work required to deliver this vital resource.

This chapter introduces a general background of how water is delivered and the regulatory framework of ensuring the workforce behind the distribution process is properly trained and certified. Chapter 2 focuses on the source of water, where our water comes from and the physical, chemical, and biological properties of one of our most precious resources. Chapter 3 enters into the regulatory framework of making our water safe to drink. The discussion will involve how and why drinking water regulations are created and the importance of complying with these ever changing regulations. Chapter 4 begins the concepts of water distribution network systems. Chapters 5 through 11 build on this concept and begin describing the underground and above ground distribution system components. The distribution system is comprised of pipes, pumps, storage facilities, valves, hydrants, meters, and a vast array of appurtenances (general term for other components), which are interconnected to bring water from the source to the tap.

The transportation of water for human consumption has been around for over 3,500 years. The Minoan civilization used tubular conduits to convey water and the Romans used intricate stone aqueduct systems to bring water great distances. In the early 1400s, cast iron pipes were introduced and in the mid 1600s, water flowed through pipes in Boston bringing spring water to

what is now known as the Quincy Market area. In the U.S in the 1700s many of the early piping systems were made of bored logs.



*Figure 1.4: Log pipes<sup>4</sup>*



*Figure 1.5: A more modern type of pipe<sup>5</sup>*

Advances in technology brought about various advancements in flow technologies and an understanding of how to efficiently and economically treat and distribute drinking water. In 1914, the first drinking water standards were established in the U.S. However, it wasn't until the early 1970s when the United States **Environmental Protection Agency (EPA)** was formed that drinking water quality standards really started to take form. Details regarding drinking water quality will be discussed in Chapter 4 of this text.

---

<sup>4</sup> [Image](#) by [kim traynor](#) is licensed under [CC BY-SA 2.0](#)

<sup>5</sup> [Image](#) by [caitriana](#) is licensed under [CC BY-SA 2.0](#)





Figure 1.6: The EPA Seal<sup>6</sup>

Although modern water distribution systems in the U.S. are relatively young, the components both under and above ground need maintenance and over time, replacement. In 2014, one of the oldest water systems in the U.S. had a major failure. A 100-year-old pipe in Philadelphia burst, releasing millions of gallons of water.



Figure 1.7: Mill Creek Sewer<sup>7</sup>

According to the Los Angeles Times, the Los Angeles Department of Water and Power has over 6,730 miles of water main pipes in their distribution network and it is estimated it will cost \$1.34 billion to replace what are considered “at risk” mains by 2025.

<sup>6</sup> EPA Seal is in the public domain

<sup>7</sup> Photo of Mill Creek Sewer is in the public domain



Figure 1.8: Damage assessment<sup>8</sup>



Figure 1.9: The Los Angeles Fire Department responding to a damaged pipe<sup>9</sup>

What does this mean? It means a few things. First of all it means there will be plenty of work (jobs) for the foreseeable future in the water utility industry. Second, it means we can expect more frequent and large water main breaks, causing at times severe damage. Lastly, it means the water utility needs to increase the amount of money spent on large improvement and replacement projects, which directly correlates to higher water rates for the consumer.

---

<sup>8</sup> [Image](#) by [Los Angeles Fire Department](#) is licensed under [CC BY-ND 2.0](#)

<sup>9</sup> [Image](#) by [Los Angeles Fire Department](#) is licensed under [CC BY-ND 2.0](#)

Water treatment and distribution are critical industries for the sustainability of modern civilization. Drinking water treatment and distribution are not the only areas within the world of water, which needs attention. Water is becoming scarcer; therefore, conservation efforts will be a way of life, especially in California. We also need to focus our efforts on the wastewater industry. As you will see in Chapter 2, water follows the hydrologic cycle, which means water passes through a continuous cycle from one phase to another. Wastewater is a process within this cycle. Humans consume and use potable water and some of it becomes wastewater. This wastewater must also go through conveyance systems, treatment, and then is discharged back into the environment. The infrastructure associated with conveying and treating wastewater must also be maintained and replaced from time to time.

Throughout this text “water companies” will be referred to in a number of different ways. Here are some of the more common terms used:

- Water Utility
- Water Agency
- Water District
- Water Company
- Public Water Supplier
- Urban Water Supplier
- Water Retailer
- Water Purveyor
- Public Drinking Water System

Do not get confused with all these different terms. In essence, they all mean the same thing. The reason there is a variety of ways to identify a company that delivers water has to do with how they are governed and how they are identified in various regulations. Just understand in this text if you read any of these terms (or possibly others), realize we are discussing the same thing.

### State Water Resources Control Board

In California, regulations governing water distribution and treatment fall under the **Division of Drinking Water (DDW)** within the **State Water Resources Control Board (SWRCB)**. The reason both agencies are identified separately is because the breadth of authority expands beyond drinking water for SWRCB. DDW regulates public water systems and is broken into three branches, the Southern California Field Operation Branch, the Northern California Field Operation Branch, and the Program Management Branch. Each branch has their own set of responsibilities and authority.

In addition to drinking water, the SWRCB is also responsible for the Regional Water Quality Control Boards (RWQCB) and functions as the regulatory authority for surface water quality and surface water rights.

### Field Operations Branches

The Southern and Northern Field Operations Branches (FOB) within DDW are responsible for the enforcement of the federal and state Safe Drinking Water Acts (SDWA). They have oversight of approximately 7,500 public water systems. Their primary responsibility is assuring the

delivery of safe drinking water to Californians. The following is a list of some of the main functions of FOB staff:

- Issue operating permits
- Review plans and specifications for new facilities
- Review water quality monitoring results
- Issue enforcement actions for non-compliance
- Conduct field inspections
- Promote water system security

FOB staff also work on recycled water projects, conservation efforts, and source water assessments. Although each FOB is empowered with the regulatory and enforcement authority over public water systems they carry the same goal and typically work closely with water industry professionals on providing safe and reliable drinking water. They provide review and oversight of water related infrastructure plans and they conduct field inspections giving guidance of how a proper distribution system should be operated.

### Program Management Branch

The Program Management Branch (PMB) within DDW works separately from the FOBs. Typically PMB staff do not work as routinely with public water system staff as the FOBs. They are charged with collecting, compiling, evaluating, and reporting water quality data from laboratories that monitor drinking water for public water systems. The PMB also coordinates emergency response and associated training and provides advice on technical matters associated with drinking water contaminants.

There are two additional sections under the PMB, the Environmental Laboratory Accreditation Program Section (ELAP) and the Technical Operations Section (TO). ELAP is responsible for evaluating and accrediting water quality testing laboratories to ensure the quality of the analytical data used for regulatory purposes to meet the requirements of the State's drinking water. TO prepares the Annual Compliance Report for the United States Environmental Protection Agency (USEPA), analyzes proposed drinking water related legislation, provides information and reports on fluoridation by public water systems and oversees the Drinking Water Additives Program.

The above descriptions and tasks associated with DDW are in no way an exhaustive list. However, it should provide the reader with a basic understanding of the overarching regulatory framework governing public water systems. In addition, to the jurisdictional authority of DDW and SWRCB, other applicable laws and standards within California legislation covering public water systems will not be discussed in this text.

### Operator Certification

Another function of DDW is of operator certification. Although the USEPA SDWA was not promulgated until 1974, laws and regulations governing the certification of potable water treatment facility operation were enacted in 1971. These rules established the

level the water treatment facilities should be manned, the minimum qualifications for testing at each of the five grade levels, and the criteria for the renewal and revocation of operator certificates. However, it wasn't until 1996, as part of the SDWA Amendments, that regulations pertaining to operator certification were enacted. In 1998, the USEPA used these amendments to establish guidelines for the certification and re-certification of operators of public water systems. These guidelines established five (5) different certification levels for both water distribution and water treatment operators. This section of the text will focus on distribution operator certification. However, the drinking water treatment certification criteria are similar. In addition, there are certifications for wastewater as well. In drinking water there are five (5) certification levels for both distribution and treatment (1 – 5). A level one (1) certification is the lowest and level five (5) the highest.

The distribution certification levels are as follows:

## Distribution

D1, D2, D3, D4, D5

The operator certification regulations provide specific requirements water utilities and their employees must follow. Title 22 regulations state “all suppliers of domestic water to the public are subject to regulations adopted by the USEPA under the SDWA as well as by the SWRCB DDW under the California Safe Drinking Water Act (CSDWA).” [Title 22, Division 4, Chapter 13](#) identifies these requirements. Each water utility is designated a certain distribution and/or treatment classification. This classification is based on a variety of different parameters. For example, a distribution system has a classification based on things such as:

- number of service connections;
- number of sources and types of supply;
- number of storage facilities; and
- type(s) of disinfection processes and chemicals used.

There are other criteria, but these are the main benchmarks used to set the classification. Once the system has its classification, it determines the level of certification the operators must obtain.

There are two types of operators: Chief and Shift. Article 1, Section 63750.25 of the above referenced chapter in Title 22, defines a Chief Operator as “the person who has overall responsibility for the day-to-day, hands-on, operation of a water treatment facility or the person who has the overall responsibility for the day-to-day, hands-on, operation of a distribution system.” Section 63750.70 defines a Shift Operator as “a person in direct charge of the operation of a water treatment facility or distribution system for a specified period of the day.” There are specific requirements in order to

become certified, which will be discussed later in this Chapter. Below is a table showing the minimum certification requirements for Chief and Shift Operators based on the classification of a distribution system.

**Table 1.1: Certification Requirements**

Distribution System Classification	Minimum Certification of Chief Operator	Minimum Certification of Shift Operator
D1	D1	D1
D2	D2	D1
D3	D3	D2
D4	D4	D3
D5	D5	D4

In addition to a Chief and Shift Operator, there are day-to-day operators who work for water utilities, but do not have any authority or decision-making responsibilities. These operators are still required to become certified, but they can hold any level based on their agencies requirements. For example, if a water utility is classified as a D5 distribution system, the employees can become D5 Distribution Operators, but may not necessarily be listed by the utility as the Chief Operator. There are specific requirements in the regulations stating what types of activities must be performed by a certified operator. A distribution water system must use only certified operators to make decisions addressing:

- installing, tapping, re-lining, disinfecting, testing, and connecting water mains and appurtenances;
- shutdowns, repairs, disinfecting, and testing broken water mains;
- flushing, cleaning, and pigging existing water mains;
- stand-by emergency response duties for after hours distribution system operational emergencies;
- draining, cleaning, disinfecting, and maintaining distribution reservoirs;
- determining and controlling proper chemical dosage rates for wellhead distribution residual maintenance; and
- investigating water quality problems in the distribution system.

While reading the above activities, some of you may be wondering what some of these terms mean. Don't worry; they will all be addressed later in this text.

### Examination Certification Eligibility Criteria

Not just anyone can become a certified operator. There are eligibility criteria for taking operator certification examinations. These criteria include completion of approved courses related to distribution and/or treatment topics, experience working in the industry with a distribution system and/or treatment plant, and holding a high school

diploma or GED. A general description of the criteria for each certification level is as follows:

- **D1 Certification** – You must have a high school diploma or GED. Although no experience is required, specific experience can be substituted for a high school diploma or GED. If you do not hold a high school diploma or GED equivalent, you must successfully complete the “Basic Small Water Systems Operations” course provided by DDW, or have one year or more experience as an operator of a facility that required an understanding of chemical feeds, hydraulic systems, and pumps.
- **D2 Certification** – You must meet the requirements of a D1 certification exam plus at least one course of specialized training covering the fundamentals of drinking water distribution or treatment.
- **D3 Certification** – You must meet the requirements of a D1 certification exam plus at least two courses of specialized training. At least one of the courses must cover the fundamentals of drinking water distribution or treatment.
- **D4 Certification** – You must have a valid D3 operator certificate plus at least three courses of specialized training. At least two of the courses must cover the fundamentals of drinking water distribution or treatment.
- **D5 Certification** – You must have a valid D4 operator certificate plus at least four courses of specialized training. At least two of the courses must cover the fundamentals of drinking water distribution or treatment.

In some instances, advanced degrees such as an Associate or bachelor’s degree can be used to fulfill operator experience. The degrees must be in specific disciplines and they only fulfill a certain amount of operator experience.

### Operator Certification Examination Content

Anyone who wishes to take an operator certification examination must meet the criteria explained above and complete the required application. This sounds easy enough. The trick is you must pass an exam in order to become certified. DDW provides the expected range of knowledge for each certification examination level. These include the following and can also be found at the following URL:

[http://www.waterboards.ca.gov/drinking\\_water/certlic/occupations/DWopcert.shtml](http://www.waterboards.ca.gov/drinking_water/certlic/occupations/DWopcert.shtml)

- Disinfection
- Distribution System Design and Hydraulics
- Equipment Operation, Maintenance, and Inspections
- Drinking Water Regulations, Management, and Safety

- Water Mains and Piping
- Water Quality and Water Sources
- Water Treatment Processes
- Laboratory Procedures
- Regulations and Administration Duties

Each one of these categories includes an array of information and topics. Textbooks like this one and courses offered at colleges, water related organizations, and private companies provide the information needed to pass certification examinations.

The operator certification information provided in this Chapter should provide you a general understanding of the operator certification guidelines and regulations. However, there is much more detail available regarding this topic. The following uniform resource locator (URL) will take you to the SWRCB website regarding Operator Certification. There you will find specific information regarding the regulations, expected range of knowledge, examinations, schedules, applications, fees, renewals, frequently asked questions, and more. While each type of certification exam will focus primarily on the main discipline (distribution or treatment), there are overlapping topics.

### Drinking Water Distribution & Treatment System Operators

The following link is a source of [guidelines for Drinking Water Treatment & Distribution System Operators](#).

#### Key Terms

- **Department of Drinking Water (DDW)** – state division within the State Water Resources Control Board that regulates public water systems and is broken into three branches, the Southern California Field Operation Branch, the Northern California Field Operation Branch, and the Program Management Branch
- **Environmental Protection Agency (EPA)** – federal agency that oversees federal drinking water quality standards
- **State Water Resources Control Board (SWRCB)** – state agency that is responsible for drinking water standards as the Regional Water Quality Control Boards (RWQCB) and functions as the regulatory authority for surface water quality and surface water rights



## Review Questions

1. What branch of the Division of Drinking Water enforces the Safe Drinking Water Acts? Briefly describe the main functions of this branch.
2. What are the goals of water utility employees?
3. How do you think water distribution has had an effect on the development of civilizations? Does it continue to have any effects and, if so, how has the focus changed over time?

## Sample Questions

1. What are the basic requirements in order to take the D1 exam?
  - a. have successfully completed one 3 unit course
  - b. have a high school diploma or equivalent
  - c. successfully completed two 3 unit courses
  - d. both a and b
2. What does SWRCB stand for?
  - a. Safe Water Regional Control Board
  - b. State Water Regional Control Board
  - c. State Water Resources Control Board
  - d. Safe Water Resources Conservation Bureau
3. What is the title of a utility worker who is in direct charge of the operation of a water distribution facility for a specified period of a day?
  - a. chief operator
  - b. shift operator
  - c. distribution operator
  - d. All of the above
4. How many levels are in water distribution certification?
  - a. 2
  - b. 3
  - c. 4
  - d. 5
5. When did humans begin to transport water in distribution systems for consumption?
  - a. 500 years ago
  - b. 1,500 years ago
  - c. 2,500 years ago
  - d. 3,500 years ago
6. Which one of the following regulations encompasses the California State Drinking Water Act?
  - a. Title 11
  - b. Title 22
  - c. Title 33
  - d. Title 44

7. Which one of the following would not be considered a main goal of a water professional?
- a. provide a safe and potable water supply to the customer
  - b. provide a reliable water supply to the customer
  - c. provide this water supply at a reasonable cost with excellent service to the customer
  - d. ensure your public retirement pension is fully funded

# CHAPTER 2 – SOURCES AND CHARACTERISTICS OF WATER

This chapter will discuss the sources of water in California and the unique characteristics of water.

## OBJECTIVES

After reading this chapter, you should be able to:

- explain the different stages of the hydrologic cycle;
- identify the various sources of supply;
- list the primary sources of supply for the southern California area; and
- discuss the physical, chemical, and biological aspects of water

## Hydrologic Cycle

### Where is Earth's Water?

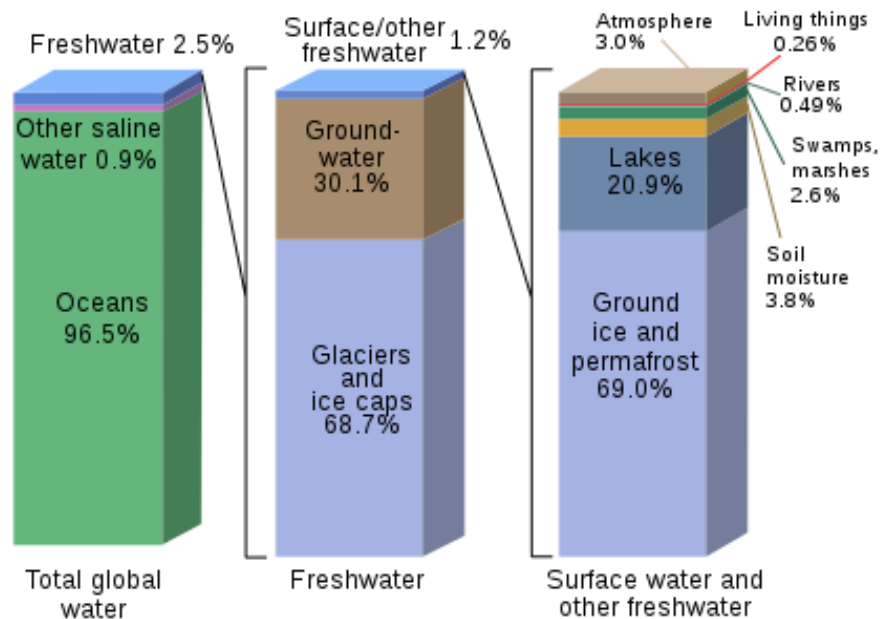

Figure 2.1: Percentages of Earth's water by location<sup>10</sup>

Where does our water come from? One of the most unique aspects of our planet is the vast amount of water covering it. About 71% of the earth's surface is water. The very thing that is essential to sustain life covers almost three quarters of our planet. However, approximately 97.5% of all the water on earth is saltwater. This means 2.5% of the planet's water is fresh water, or water not containing salt. While this is still a lot of

<sup>10</sup> [Image](#) by the [USGS](#) is in the public domain

water, almost 70% of it is inaccessible. This water is in the form of glaciers or permanent snow cover. Approximately 31% of this water is groundwater and less than 1% is considered surface water.

Does this mean we will eventually run out of fresh water? If the majority of the earth's water is either salt water or inaccessible, does it mean we have a limited supply to sustain life? The short answer is no, we will not run out of fresh water and we do not have a limited supply. However, access to fresh water is an issue that needs to be addressed, and there are places on our planet which lack safe and adequate supplies of drinking water. In this section, we will address the "short answer". The reason we have access to fresh water in most areas on earth has to do with something known as the hydrologic cycle. The **hydrologic cycle** is the continuous movement of water throughout earth involving evaporation, condensation, precipitation, infiltration, and surface runoff. Water changes from one form to another and then another. The three phases water passes through are liquid, gas, and solid. We understand and encounter water in these three phases on a daily basis. Water in its most common form is liquid. However, we can freeze it to make ice (solid) or boil it to encounter steam (gas). Throughout the hydrologic cycle, water also transfers through these phases.

The image below shows a lot of detail regarding the hydrologic cycle. First try to focus on the three phases we just discussed (liquid, gas, and solid). Precipitation is the liquid state, ice and snow the solid state, and evaporation represents the gas or vapor state. As you can see from this diagram, water passes through these three phases (states) in a continuous movement on, above, and below the surface of the earth.

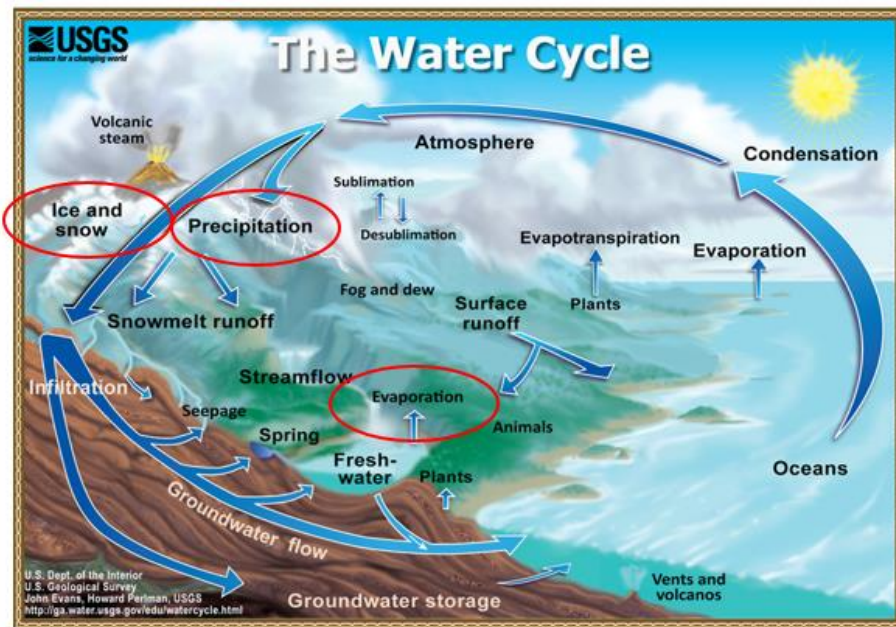

Figure 2.2: The hydrologic cycle<sup>11</sup>

<sup>11</sup> [Image](#) by the [USGS](#) is in the public domain

**Evapotranspiration** is the process of water transferring from the land to the atmosphere from the soil and other surfaces and by transpiration from plants. **Transpiration** is the evaporation from plant leaves. Think of it as plants sweating. **Sublimation** is the process by which a substance (water in this case) passes directly from the solid phase to the vapor or gaseous phase. This typically happens in the atmosphere. The third term is **infiltration**. Infiltration is the process of water entering the ground surface. If geological conditions are right, the water will continue transferring deeper into the earth's surface until it becomes groundwater. This deeper transferring process is known as **percolation**. The only other process in the hydrological cycle you should take note of is the process of **condensation**. This is when water vapors transition from the gas phase to the liquid phase. Now that we have a general understanding of the hydrologic cycle, it's time to turn our attention to the various sources of water supply.

## Water Sources

### Surface Water

As water leaves the oceans and other areas on land, it evaporates in to the atmosphere and eventually comes back down through some form of precipitation. As snow and ice melt or rain falls on land it becomes runoff. This runoff will enter streams, rivers, or lakes. Each of these surface water projects below serve specific areas and are owned and operated by different water agencies.

- **Los Angeles Aqueduct** – The LA Aqueduct is owned and operated by Los Angeles Department of Water and Power (LADWP). The only users of this water are the customers of LADWP. The aqueduct took approximately five years to construct and originates in the Owen's Valley, bringing water to LADWP customers through an all gravity system.
- **Central Valley Project** – The Central Valley Project is a water distribution system that brings water for irrigation for farmers as well as urban use. It also provides some flood protection to the Central Valley. It is managed and operated by the federal Bureau of Reclamation.
- **Colorado River Aqueduct** – The Colorado River Aqueduct brings water from the Colorado River at Lake Havasu to Southern California. It is operated by Metropolitan Water District. The water flows through two reservoirs and five pumping stations and delivers water as far south as San Diego County.
- **State Water Project** – The State Water Project is one of the largest public water utilities in the world. It brings water from Northern California and distributes it to areas in and around San Francisco and to the major metropolitan areas of Southern California. It is maintained by the California Department of Water Resources and has twenty-nine different contractors pulling water from this

system. There are more than a dozen water storage reservoirs and pumping plants within this system.

According to the USGS approximately 80% of all water used in the United States comes from surface water sources. Surface water is an important natural resource used for many purposes, especially irrigation and public drinking water supply.

### Groundwater

Groundwater originates from water on the surface, which infiltrates and eventually percolates deep enough into underground systems known as aquifers. An aquifer is an underground system of permeable soil (sand, gravel, rock), which can contain and transmit water underground or groundwater. Groundwater exists for two main reasons, gravity and geologic formation.

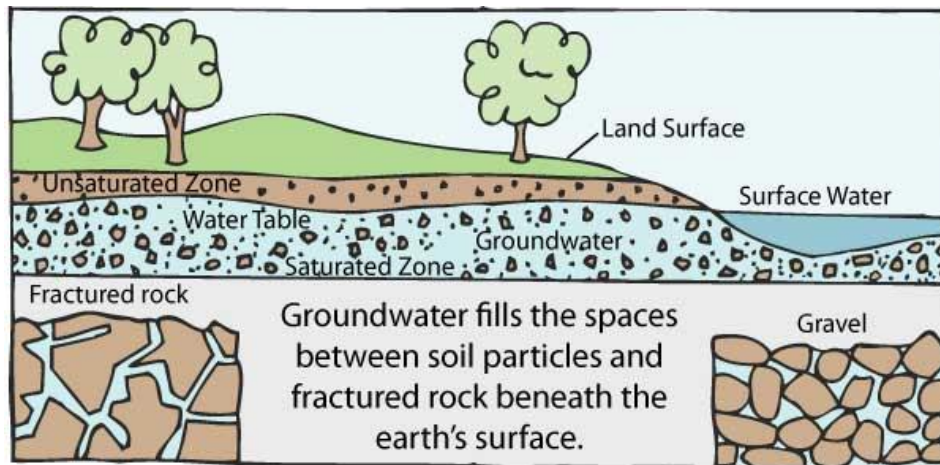

Figure 2.3: Groundwater movement<sup>12</sup>

Gravity pulls the water into the earth and if the geologic formation is conducive to holding water, aquifers will form. Water accumulates in the voids and spaces within the underground geology. Some examples of these formations consist of sandstone, limestone, and even granite. There are three main types of aquifers, unconfined, confined, and fractured rock. Each of these has unique characteristics and properties.

- **Unconfined Aquifer** – An unconfined aquifer has the upper surface open to the atmosphere through permeable material such as sand and gravel. This type of aquifer is typically more susceptible to contamination from spills or discharges on the ground surface.
- **Confined Aquifer** – A confined aquifer has a similar composition as unconfined aquifers. They consist of porous materials such as sand and gravel. The main distinction is there is an overlying and underlying impervious rock or clay layer

<sup>12</sup> This [material](#) was reproduced from groundwater.org with the permission of The Groundwater Foundation. © The Groundwater Foundation. All Rights Reserved.

separating it from the atmosphere. Commonly, this impervious layer consists of clays. Because of this impervious layer, confined aquifers are generally less susceptible to contamination.

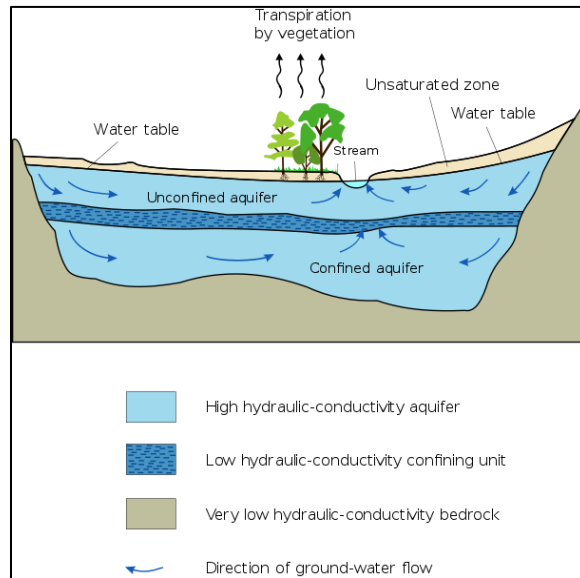

Figure 2.4: Aquifers<sup>13</sup>

- **Fractured Rock** – An underground fractured rock system is much different than unconfined and confined aquifers. In some areas there are rock formations, which have little to no permeability, but they still can contain water. The water is stored in complex fractures (cracks) within the rock formation. This water can be withdrawn, but the variability of the fractures makes it more difficult to locate the areas with water.

Both unconfined and confined aquifers can yield large quantities of water for domestic and agricultural use. Many communities rely solely on groundwater from these types of aquifers. While fractured rock can store water underground, these types of aquifer are not as common and do not produce nearly as much water. In the southern California area there are many different aquifers systems. According to the California Department of Water Resources (DWR) there are seventy-seven groundwater basins and subbasins in the South Coast Hydrologic Region. This includes the counties of:

- Ventura
- Los Angeles
- San Bernardino
- Riverside
- Orange
- San Diego

<sup>13</sup> [Image](#) by Hans Hillewaert is licensed under [CC BY-SA 3.0](#)



Figure 2.5: Californian basin map<sup>14</sup>

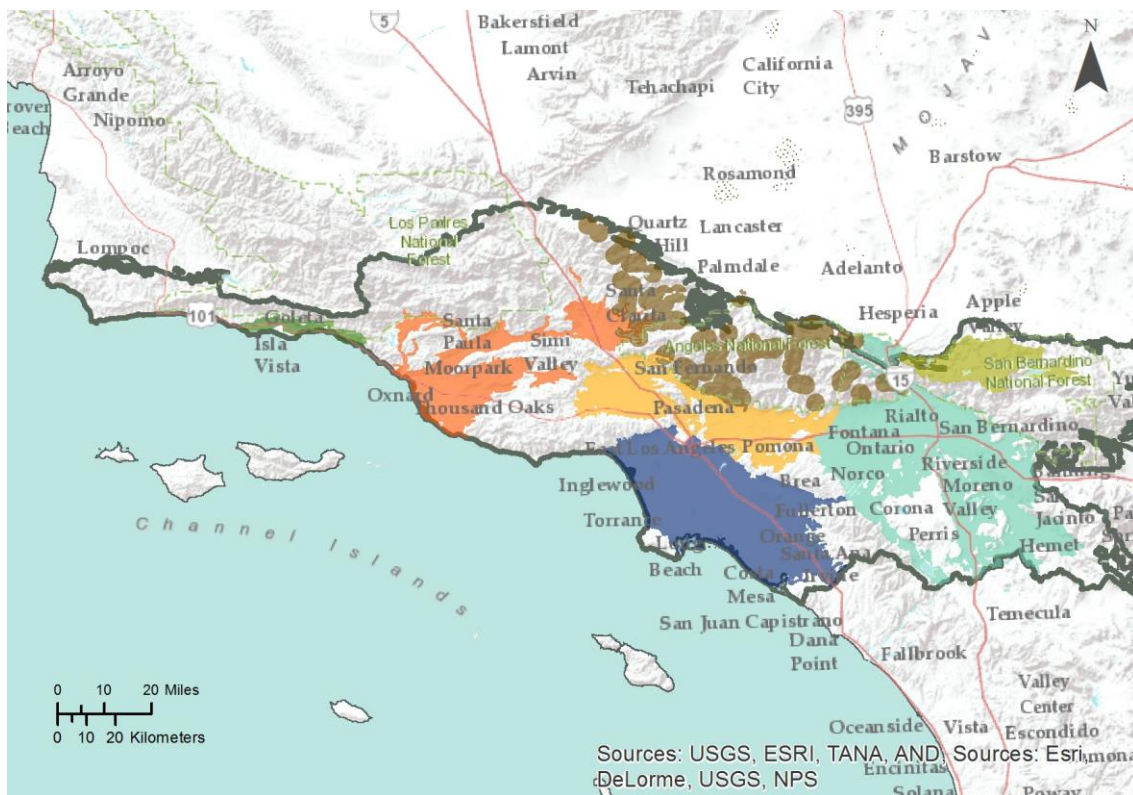

The Transverse Ranges and Selected Peninsular Ranges Province consists of the following Study Units:

- Santa Barbara Basin
- San Gabriel Mountains
- Santa Clara River Valley
- San Gabriel / San Fernando
- Santa Ana Basin
- Big Bear Basin
- Coastal Los Angeles Basin

### Recycled Water

Reclaimed water is water that is treated for any process other than potable use. Recycled water is a type of reclaimed water produced by a reclamation plant. **Recycled water** is treated wastewater. All wastewater travels through a network system of sewer pipelines. This network is primarily a gravity flow system, but at times when elevations change, pumps are required to “lift” the wastewater. Once the wastewater arrives at a wastewater reclamation plant (wastewater treatment plant is also commonly used), it must go through a treatment process. The treatment requirements for ultimate discharge vary depending on where the treated wastewater will be released. Sometimes these treatment plants are located along the coast and the water is discharged to the

<sup>14</sup> [Map](#) by the [USGS](#) is in the public domain

ocean. While other times, plants are located in inland communities and the water is discharged in local river systems.

In order for treated wastewater to be used as recycled water, it must at least go through tertiary treatment. The first two stages of wastewater treatment (primary and secondary) are designed to remove the debris and solids through a sedimentation process and then a process to remove the biological content. The tertiary treatment process is usually the last stage of treatment, unless some form of advanced treatment is used. Typically, this process involves some form of filtration, which includes sand. Additional nutrients can also be removed.

While recycled water typically meets all state and federal drinking water standards, it is not allowed for human consumption. The primary use for recycled water is irrigation. Parks, playgrounds, sports fields, street and freeway landscaping, and golf courses are some of the more common uses of recycled water. Recycled water can also be used for industrial and commercial cooling systems.

### Water Characteristics

Water is an amazing compound and has some very unique properties. Because of the molecular structure of water, it has an affinity for other molecules. Water is considered a “polar” compound. This means there is an uneven distribution of the electron density. The bonds between the oxygen atom and two hydrogen atoms are at an angle.

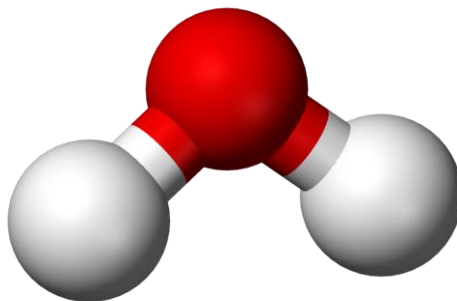

Figure 2.6: Water molecule<sup>15</sup>

The red dot above represents the oxygen atom in water and the two white dots represent the hydrogen atoms, which equates to the molecular formula “H<sub>2</sub>O”. The structure of water has a partial negative charge near the oxygen and partial positive charge near the hydrogen atoms. This structure allows water to have interesting properties. **Cohesion** is the ability of water to be attracted to other water molecules. This cohesive property is what gives water surface tension and allows insects such as a Water Strider to walk on water. This polarity also allows water to dissolve many different compounds.

---

<sup>15</sup> [Photo](#) by [Benjah-bmm27](#) is in the public domain



Figure 2.7: A gerris on water<sup>16</sup>

Water also has an attraction between molecules referred to as **adhesion**. When you fill a glass with water the water around the glass “adheres” to the glass causing the water to “climb” the glass wall. This results in the water having a meniscus a concave appearance.

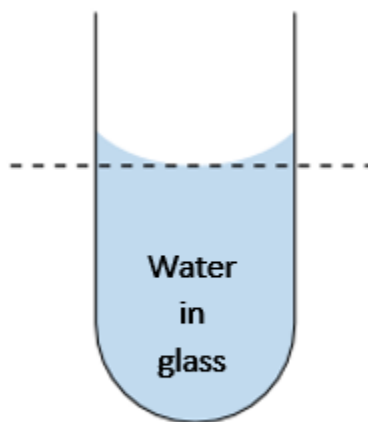

Example of a Concave Meniscus

Figure 2.8: Adhesion<sup>17</sup>

Water is also the only common substance on the earth’s surface, which exists as a gas, liquid, and solid. Temperature effects water by causing it to persist in each one of these phases. It is typically a colorless and odorless substance.

### Physical Characteristics

Water is generally colorless. This is one of the most important aesthetic qualities of water, which customers care about. No one wants to drink water that has a color. However, this is also a common problem water quality professionals have to monitor.

<sup>16</sup> [Photo](#) by webrunner is licensed under [CC BY-SA 3.0](#)

<sup>17</sup> [Image](#) by Jleedev is licensed under [CC BY-SA 3.0](#) (image modified by [COC OER](#))

There are several things in the distribution system, which can cause water to have a color. Some examples include, air (white), iron (yellow or brown), manganese (causing black stains). There are solutions to these examples, but it is important for water utility professionals to monitor their water quality within the distribution system in order to keep water in its natural colorless state.

In addition to being colorless, water typically doesn't have a taste. However, much like color, certain things in the water supply can give water an unpleasant taste. Chlorine is a chemical commonly used to disinfect water in order to make it safe to drink. However, this can also give water an unpleasant taste to customers.

The final physical property of water we will discuss in this text is temperature. As the temperature of water changes, the physical nature of water also changes. For example, as water approaches 0°C it changes form from a liquid to a solid. Conversely, as water approaches 100°C, it starts to boil and transitions from a liquid to a gas.

#### Key Terms

- **adhesion** – the physical property caused by attraction of molecules that allows water to “stick” to the glass when you fill a glass with water; the meniscus is evidence of adhesion
- **cohesion** – the ability of water to be attracted to other water molecules that allows insects to seemingly walk on water
- **confined aquifer** – an aquifer of sand and gravel with an overlying and underlying impervious rock or clay layer
- **evapotranspiration** – the process of water transferring from the land to the atmosphere from the soil and other surfaces and from transpiration from the plants
- **fractured bedrock** – where the water is stored in complex fractures (cracks) within the rock formation
- **hydrologic cycle** – continuous movement of water throughout the earth
- **infiltration** – the process of water entering the ground surface
- **percolation** – the process of water moving from shallow to deep
- **recycled water** – treated wastewater (through tertiary treatment) that can be used for irrigation and non-potable uses
- **sublimation** – the process through which a substance passes from a solid to a gas (without being a liquid)
- **transpiration** – the evaporation from plant leaves
- **unconfined aquifer** – an aquifer that has the upper surface open to the atmosphere through permeable material such as sand and gravel

## Review Questions

1. Briefly describe the hydrologic cycle including each of the phases.
2. What is the key difference between a confined and unconfined aquifer?
3. What is the role a water agency should play in groundwater management and source water protection?

## Sample Questions

1. Which one is not one of the phases of water throughout the hydrologic cycle?
  - a. liquid
  - b. gas
  - c. solid
  - d. sublimation
  
2. What is the name for treated wastewater used for irrigation?
  - a. non-potable water
  - b. irrigated supply water
  - c. agriculture water
  - d. recycled water
  
3. Which describes water generally?
  - a. colorless
  - b. unsafe to drink
  - c. abundant in all areas
  - d. all of the above
  
4. Which of the following would not be considered an aquifer?
  - a. confined
  - b. unconfined
  - c. aqueduct
  - d. fractured rock
  
5. Which is not a California water infrastructure project?
  - a. Los Angeles Aqueduct
  - b. Columbia River
  - c. Colorado River
  - d. State Water Project

# CHAPTER 3 – REGULATIONS AND WATER QUALITY

This chapter will examine water quality from a distribution system perspective.

## OBJECTIVES

After reading this chapter, you should be able to:

- differentiate between the primary sources of drinking water contamination;
- evaluate the water quality sampling requirements within a distribution system;
- summarize the main federal and state water quality regulatory citations; and
- explain the role the American Waterworks association plays in terms of water quality standards.

## Is My Water Safe to Drink?

One of the biggest questions and concerns people have is whether or not their tap water is safe to drink. However, sometimes there is confusion between the taste, odor, and appearance of the water and the actual “safety” of the water. Many times these two things are not one and the same. Tap water can be discolored, smell strange, and have an odd taste, but from a health and safety standpoint, the water might be perfectly fine. Explaining this to a customer can be a very challenging task. Conversely, a glass of water might be crystal clear and have no apparent taste or odor and could be potentially unsafe (non-potable) for human consumption.

So, how does a water quality professional handle variability in the quality of drinking water? There are several tools that water treatment and distribution operators use to make sure the water they are providing to millions of people is safe and to a certain extent “pleasant” to drink. The word pleasant is placed in quotes, because things like taste, odor, and color can be very subjective characteristics in terms of drinking water quality.

The tools water utility professionals use can be explained in four main categories: regulations, treatment, testing, and maintenance.

Each one of these categories will be explained throughout this chapter, but below is a concise explanation of each one.

- **Regulations** – Drinking water quality regulations might be the number one component to ensure a safe drinking water supply is being provided to water utility customers. The United States Environmental Protection Agency (USEPA) is tasked with providing minimum drinking water standards for water utilities throughout the United States to adhere to. These drinking water regulations are

found in the Safe Drinking Water Act (SDWA). Among other things, the SDWA sets minimum levels for a variety of contaminants in drinking water.

- [USEPA Safe Drinking Water Act](#)
- [California Safe Drinking Water Act](#)
  
- **Treatment** – Within the SDWA, there are rules and regulations regarding the treatment requirements at drinking water treatment plants. Along with the minimum contaminant levels, there are various treatment technologies for drinking water treatment plants.
  
- **Testing** – The SDWA also spells out testing requirements for water utilities at treatment plants, at the various sources of supply, and within distribution systems. Additional sampling is also common for a variety of other reasons not spelled out in the regulations. Collecting and analyzing water quality samples is not only a regulatory requirement, it is used by treatment and distribution operators for monitoring and predicting water quality.
  
- **Maintenance** – Maintenance (especially within distribution systems) goes a long way with improving and maintaining good water quality. Some of the more common distribution maintenance tasks associated with improving and maintaining good water quality are flushing of water mains and cycling the level of water in storage tanks.

Providing and maintaining a safe supply of drinking water to customers is a primary responsibility of all water utilities. This is achieved through the items discussed above as well as a collaborative and coordinated effort between water utility staff, regulators, and the public receiving this vital resource.

In addition to the regulatory requirements, the American Water Association (AWWA) provides a variety of standards and guidance to water utilities. AWWA is an international, nonprofit, scientific, and educational organization. It was established in 1881 and is the largest Association of water supply professionals in the world. The recent State Water Resources Control Board Division of Drinking Water's (DDW) waterworks standards were revised in 2008 and most were based on AWWA recommendations and standards.

### Sources of Contamination

There are a number of naturally occurring and manmade contaminants, which can be found in water supplies. These contaminants can be broken down into four main categories; physical, biological, chemical, and radiological. Because the sources of drinking water supply vary from region to region, the contaminants present in one part of the world are not necessarily found in other parts of the world. For example, a constituent such as fluoride is temperature dependent and therefore is not typically



found in groundwater supplies in cooler regions but may be found in warmer climate regions.

### Physical Contamination

Most physical contaminants do not pose a direct health effect. They primarily impact the appearance of drinking water. Physical contamination is more commonly found in surface water supplies and often results from soil erosion. Sediments and organic material can wash off surrounding hillsides along lakes, rivers, and streams. These contaminants mostly effect the aesthetic quality of drinking water, such as the taste, odor, and color. However, these types of contaminants can also impede the drinking water treatment process and can act as a barrier protecting biological contaminants.

### Biological Contamination

One of the most common contaminants water utilities collect samples and analyze are part of the biological class of contaminants. While only a few bacteriological organisms are pathogenic, this entire class of organisms can wreak havoc on a water system. From a public health standpoint, we are mainly concerned with the bacteriological and viral disease causing (pathogenic) organisms. Since it can be difficult and costly to try and analyze all the different strands of viruses and bacterial organisms, which might find their way in to a water system, an “indicator” organism is preferred. In drinking water supplies and systems, the indicator of choice is the total coliform group. Pathogenic organisms include those derived from fecal contamination and viruses, which typically use bacteria as a host for replication. These disease causing organisms which can be found in drinking water include, but are not limited to *Escherichia coli* (*E. coli*) and various strains of *Vibrio* and *Enterococcus*, various enteroviruses, and parasites such as *Cryptosporidium* and *Giardia*. Most of these organisms find their way into a drinking water system through some type of contamination with fecal matter. Perhaps an animal feed lot is upstream from a water supply or an underground sewer collection system is leaking next to a drinking water underground well. Therefore, the main source for these contaminants is human or animal feces.

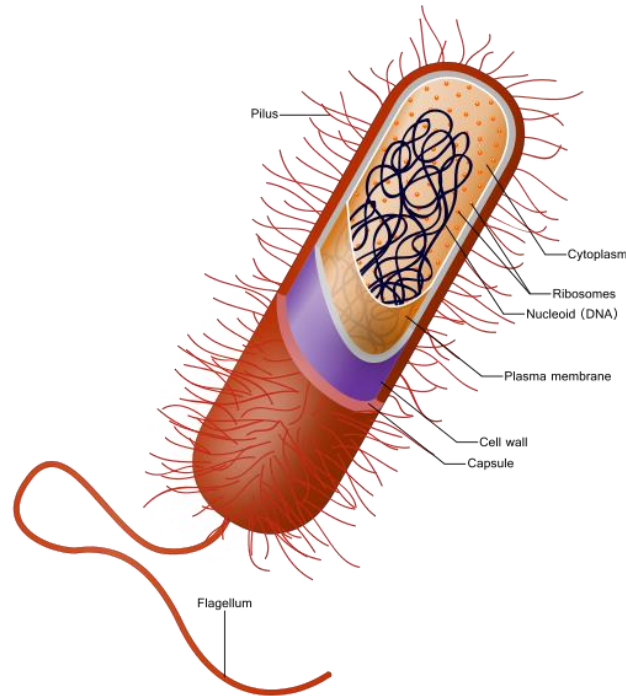

Figure 3.1: Prokaryote cell<sup>18</sup>

All of these potential contaminants are routinely monitored through a regulation called the Total Coliform Rule (TCR). In 2013 and 2014, revisions to the 1989 TCR were implemented in order to improve public health. The TCR is now referred to as the Revised Total Coliform Rule (RTCR). Total coliforms are a group of related bacteria, which are (with few exceptions) not harmful to humans. Therefore, the USEPA has identified this group of organisms to represent an indicator for a variety of bacteria, viruses, and parasites which are known pathogens and can cause health problems in humans if they are ingested.

### Revised Total Coliform Rule

The USEPA published the Revised Total Coliform Rule (RTCR) in the Federal Register on February 13, 2013 (78 FR 10269) and minor corrections on February 26, 2014 (79 FR 10665). Promulgation of the RTCR began on April 1, 2016.

Most of the major provisions of the TCR stay in place and include:

- Collecting total coliform (TC) samples at representative locations throughout the distribution system.
- Samples must be collected at regular intervals.
- Numbers of samples collected are based on the size of the population the water utility serves.
- Repeat sampling is required for positive results, which include analysis of *E. coli*.

---

<sup>18</sup> [Image](#) by [Ali Zifan](#) is licensed under [CC BY-SA 3.0](#)

Details of the TCR can be found in the [USEPA's Total Coliform Rule: A Quick Reference Guide](#).

The main changes to the RTCR include the following:

- Setting a maximum contaminant level goal (MCLG) and maximum contaminant level (MCL) for *E. coli*.
- Setting a TC treatment technique (TT).
- Requirements for assessments and corrective actions.
- Specific language in the annual Consumer Confidence Reports (CCR) for violations.

Details of the RTCR can be found in the [USEPA's Revised Total Coliform Rule: A Quick Reference Guide](#).

There are a number of different provisions within each rule and depending on the size of the utility, there are different requirements. In general, every TC positive sample must be followed up with analysis of *E. coli* and repeat samples are also required. At least three (3) repeat samples are required for every TC positive sample. The repeat samples must be collected within 24 hours of learning about the positive TC result. The repeat samples must be collected from the same sample location and within five (5) service connections upstream and downstream of the original sample location. There are additional requirements, but more detail is beyond the scope of this text.

## Chemical Contamination

There are many different chemicals used in the world for a variety of different things. For example, arsenic is used to preserve wood and prevent rotting and chromium is used in chrome plating processes. While chemicals are commonly used in various manmade processes, they are also found naturally occurring in the environment. Regardless of the source of contamination (naturally occurring or manmade), if they pose a threat to public health they also need to be regulated if they are found in drinking water supplies. Within this group of contaminants, there are two main categories; inorganic and organic. The main difference between these two categories is the absence of carbon with inorganic chemicals and the presence of carbon with organic chemicals. Below is a short list of common contaminants found in drinking water supplies within both categories.

- **Common Inorganic Chemicals** – While most of these inorganic chemicals can be found naturally occurring in water supplies. Except for arsenic, most common inorganic chemicals are the result of contamination from human activities.
  - Arsenic (As) – As previously mentioned, one of the main uses of arsenic is preserving wood. Arsenic is also commonly found naturally in groundwater supplies, especially in the southwest.

- Nitrate (NO<sub>3</sub>) – While nitrate can be found naturally occurring, these levels are relatively harmless. The primary sources of nitrate in drinking water are from fertilizers and contamination from sewage.
  - Chromium (Cr) – Chromium is used in plating processes and can also be found naturally in the environment. One of the unique things about chromium is it is found in two common oxidative states, Cr III and Cr VI.
  - Lead – Lead is most commonly found in plumbing systems, although the allowable levels are being reduced because of the significant health effects. The main reason lead was used in plumbing supplies is because of its malleability.
  - Copper – Copper is also most commonly found in plumbing supplies.
- **Common Organic Chemicals** – The organic chemicals found in drinking water supplies are referred to as volatile organic compounds (VOCs) and synthetic organic compounds (SOCs). While they can be found naturally occurring, the majority of the VOCs and SOCs found in drinking water supplies are from manmade chemicals.
    - Trichloroethylene (TCE) – TCE is a common solvent used as a degreaser.
    - Tetrachloroethylene (PCE) – PCE is a common solvent used in dry cleaning
    - Methyl tertiary-butyl ether (MTBE) – A gasoline additive to help improve air quality.

## Drinking Water Standards

In order to make sure contaminants are limited or kept at levels below those which would pose health effects to consumers, there are a number of regulatory standards in the SDWA. In addition to the federal SDWA, some states have their own set of standards water utilities must adhere to. In California under Title of the California Code of Regulations, there is the California Safe Drinking Water Act (CSDWA). The difference between federal and state drinking water regulations is the ability of state regulations to be more stringent than federal regulations. This means that the CSDWA can have regulatory levels for contaminants set at a lower level than the federal SDWA. They cannot be set higher. Within the SDWA, contaminants are separated into two main categories, primary drinking water standards and secondary drinking water standards. Primary standards are for those chemicals which pose a public health threat. Secondary standards are for contaminants, which have aesthetic effects on the water supply. The USEPA goes through an extensive process in order to determine if a contaminant needs to be regulated under the SDWA. There are three main criteria the USEPA considers in order to make a regulatory determination. They determine whether or not the contaminant meets the following criteria:

- The contaminant may have an adverse effect on the health of persons;

- The contaminant is known to occur or there is substantial likelihood the contaminant will occur in public water systems with a frequency and at levels of public health concern;
- In the sole judgment of the Administrator, regulation of the contaminant presents a meaningful opportunity for health risk reductions for persons served by public water systems.

Once the USEPA identifies whether or not a contaminant needs to be regulated, further evaluation is required to determine the technical and economic feasibility of regulating the contaminant. During this process, a non-enforceable level is usually established. This non-enforceable level is referred to as a **Maximum Contaminant Level Goal (MCLG)**. MCLGs are set at levels which no known or anticipated adverse health effect would occur. The next step is to develop an enforceable standard referred to as a **Maximum Contaminant Level (MCL)**. MCLs are set as close to the MCLG as is feasible. The SDWA defines “feasible” as the level that may be achieved with the use of the best available technology or treatment techniques the USEPA finds available (under field conditions and not solely under laboratory conditions), taking cost into consideration. The USEPA can establish a regulatory treatment technique when there is no reliable method that is economically and technically feasible to measure a contaminant. In addition to MCLs and MCLGs, there are other acronyms related to drinking water quality regulations. These include the following:

- **PHG** – Public Health Goals are similar to MCLGs. They are California non-enforceable standards where an MCL does not exist.
- **AL** – Action Levels are set for certain contaminants where an MCL does not exist and some type of response (action) is required by the water utility if an AL is exceeded.
- **DLR** – Laboratories are tasked with analyzing contaminants. As laboratory techniques improve, these levels become smaller (lower) over time. The Detection Limit for Reporting is set at a level laboratories can accurately reproduce with the current method of analysis.

The level of a contaminant is expressed using a ratio of units. The most common units used to express levels of contaminants are the following:

- Milligram per liter (mg/L)
- Microgram per liter (ug/L)
- Nanogram per liter (ng/L)

The above examples express the weight of the contaminant in a liter of water. Therefore, a level of 10 mg/L means that for every liter of water there are 10 mg of a substance. Sometimes, alternative units of measure are used. These alternatives are the following:

- Parts per million (ppm) = mg/L

- Parts per billion (ppb) = ug/L
- Parts per trillion (ppt) = ng/L

These units mean for every part of a contaminant there are a million, billion, or trillion parts of water. For example, a level of 10 ppm (same as 10 mg/L) means that for every million parts of water, there are 10 parts of the substance.

While it is not required for water distribution operators to memorize drinking water quality standards (MCLs), it is important for them and especially the water quality professionals to have a general understanding of the main contaminants within their water supply. In addition, it is important for water quality professionals such as water quality technicians, specialists, supervisors, and managers to understand the health effects associated with common contaminants. Some of the more commonly found primary contaminants in drinking include the following:

- Nitrate
- Arsenic
- Radiological Compounds
- Lead and Copper

#### Nitrate

Nitrate – MCL = 45 mg/L as NO<sub>3</sub> or 10 mg/L as N – The reason there are two MCLs for nitrate is because the value can be expressed as actual amount of nitrate (NO<sub>3</sub>) or expressed as the total amount of nitrogen (N).

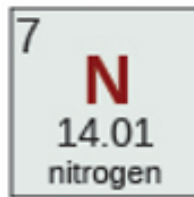

Figure 3.2: Nitrogen on the periodic table<sup>19</sup>

- **Source** – The primary source of nitrate in drinking water is from fertilizers. This is especially present in areas where there is or was agriculture present. Nitrate can also occur as a result of contamination from animal or human sewage waste.
- **Health Effects** – The primary health effect associated with elevated levels of nitrate in drinking water is something referred to as “blue baby syndrome”. The medical diagnosis is methemoglobinemia. It is a condition, which effects the body’s ability to release oxygen to tissues. Infants six months old and younger are particularly susceptible.

<sup>19</sup> [Image](#) by [OpenStax](#) is licensed under [CC BY 4.0](#) (image modified by [COC OER](#))

## Arsenic

Arsenic – MCL = 10 ug/L

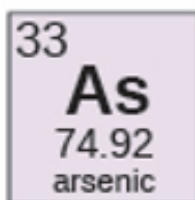

Figure 3.3: Arsenic on the periodic table<sup>20</sup>

- **Source** – Arsenic is found naturally in certain geologic formations and is also used in some industries. One common use is a preservative for wood products.
- **Health Effects** – Studies have linked long-term exposure to arsenic in drinking water to cancer of the bladder, lungs, skin, kidney, nasal passages, liver and prostate. Non-cancer effects of ingesting arsenic include cardiovascular, pulmonary, immunological, neurological, and endocrine effects.

## Radiological Compounds

There are several types of radiological compounds found in drinking water supplies and include; uranium, strontium, total alpha, and total beta.

- **Source** – The primary source of radiological compounds in drinking water is naturally occurring geologic formations. Accidental or intentional releases from human activities is a rare occurrence.
- **Health Effects** – Elevated levels of radiological compounds in drinking water can increase the risk of kidney damage.

## Lead and Copper

Lead and Copper – AL = 15 ug/L for Lead (Pb) and 1,300 ug/L for Copper (Cu) – Lead and copper contamination does not typically occur in the source water or even in the distribution system of drinking water systems. The primary source of lead and copper contamination occurs in internal plumbing systems. Lead and copper are commonly used in the manufacturing of plumbing supplies and can leach out into drinking water. Therefore in 1991, the Lead and Copper Rule (LCR) was passed. The LCR requires water utilities to collect samples for lead and copper within customer homes. While lead and copper is not as common within distribution systems, it is an issue in older communities where lead service laterals and other materials were commonly used. The most recent discovery of lead contamination within a distribution system was in 2014 in Flint, Michigan. As a result, the LCR is going through a number of different revisions.

---

<sup>20</sup> [Image](#) by [OpenStax](#) is licensed under [CC BY 4.0](#) (image modified by [COC OER](#))

- **Health Effects** – The primary effects of copper in drinking water are related to gastrointestinal issues. However, the effects from lead in drinking water are far worse and include damage to the brain, red blood cells, and kidney.

As previously mentioned, secondary drinking water contaminants are not health related. The problems associated with secondary contaminants can be grouped into three categories:

- **Aesthetic effects** – undesirable tastes or odors
- **Cosmetics effects** – effects which do not damage the body but are still undesirable
- **Technical effects** – damage to water equipment or reduced effectiveness of treatment for other contaminants

The periodic table lists the various chemical substances that can be found in water supplies. Below is an image of the periodic table with many of the ions mentioned below circled for reference:

B = Solids    Hg = Liquids    Kr = Gases    Pm = Not found in nature

1 H 1.00794																	2 He 4.002602
3 Li 6.941	4 Be 9.012182											5 B 10.811	6 C 12.0107	7 N 14.00674	8 O 15.9994	9 F 18.9984032	10 Ne 20.1797
11 Na 22.989770	12 Mg 24.3050									13 Al 26.981538	14 Si 28.0855	15 P 30.973761	16 S 32.066	17 Cl 35.4527	18 Ar 39.948		
19 K 39.0983	20 Ca 40.078	21 Sc 44.955910	22 Ti 47.867	23 V 50.9415	24 Cr 51.9961	25 Mn 54.938045	26 Fe 55.845	27 Co 58.933200	28 Ni 58.6534	29 Cu 63.545	30 Zn 65.39	31 Ga 69.723	32 Ge 72.61	33 As 74.92160	34 Se 78.96	35 Br 79.504	36 Kr 83.80
37 Rb 85.4678	38 Sr 87.62	39 Y 88.90585	40 Zr 91.224	41 Nb 92.90638	42 Mo 95.94	43 Tc (98)	44 Ru 101.07	45 Rh 102.90550	46 Pd 106.42	47 Ag 107.8682	48 Cd 112.411	49 In 114.818	50 Sn 118.710	51 Sb 121.760	52 Te 127.60	53 I 126.90447	54 Xe 131.29
55 Cs 132.90545	56 Ba 137.327	71 Lu 174.967	72 Hf 178.49	73 Ta 180.9479	74 W 183.84	75 Re 186.207	76 Os 190.23	77 Ir 192.217	78 Pt 195.078	79 Au 196.96655	80 Hg 200.59	81 Tl 204.3833	82 Pb 207.2	83 Bi 208.98038	84 Po (209)	85 At (210)	86 Rn (222)
87 Fr (223)	88 Ra (226)	103 Lr (262)	104 Rf (261)	105 Db (262)	106 Sg (263)	107 Bh (262)	108 Hs (265)	109 Mt (266)	110 Ds (269)	111 Rg (272)	112 Cn (277)	113 Uut (277)	114 Uuq (277)	115 Uup (277)	116 Uuh (277)		
		57 La 138.9055	58 Ce 140.116	59 Pr 140.90765	60 Nd 144.24	61 Pm (145)	62 Sm 150.36	63 Eu 151.964	64 Gd 157.25	65 Tb 158.92534	66 Dy 162.50	67 Ho 164.93032	68 Er 167.26	69 Tm 168.93421	70 Yb 173.04		
		89 Ac 232.0381	90 Th 232.0381	91 Pa 231.03888	92 U 238.0289	93 Np (237)	94 Pu (244)	95 Am (243)	96 Cm (247)	97 Bk (247)	98 Cf (251)	99 Es (252)	100 Fm (257)	101 Md (258)	102 No (259)		

Figure 3.4: The periodic table<sup>21</sup>

Contaminants related to color, odor and taste (aesthetic) include:

- Chloride (Cl), Copper (Cu), Foaming Agents, Iron (Fe), pH, Sulfate (SO<sub>4</sub>), Manganese (Mn), Total Dissolved Solids (TDS), and Zinc (Zn).

<sup>21</sup> [Image](#) by [Saylor Academy](#) is licensed under [CC BY-NC-SA 3.0](#) (image modified by [COC OER](#))



Contaminants related to cosmetic effects include:

- Silver (Ag) and Fluoride (F).

Contaminants related to technical effects include:

- Chloride, Copper, Corrosivity, Iron, Manganese, pH, and Total Dissolved Solids.

Some of the chemical contaminants listed above are compounds or in the case of TDS, are a combination of ions. Sulfate for example is a sulfur ion combined with four oxygen atoms. TDS represents a number of different constituents which include but are not limited to calcium, magnesium, sulfate, chloride, as well as others.

## Disinfection

One of the most critical processes in the area of water quality is the ability to control the growth and regrowth of pathogenic organisms throughout the distribution system. This process is commonly handled through disinfection. By definition, disinfection is the process of cleaning something, especially with a chemical, in order to destroy bacteria. Disinfection should not be confused with other processes such as sanitation or sterilization. Sanitation is the process to make something clean, but it doesn't necessarily target disease causing organisms and sterilization is the process of ridding something of all bacteria. The goal of drinking water disinfection is to destroy pathogenic organisms in order to make it safe for human consumption. This process is commonly achieved through the use of chlorine and chlorine related compounds or other oxidants.

## Physical Disinfectants

While not common, microorganisms can be inactivated in water supplies through physical means. These include, but are not limited to ultraviolet rays, heat, and ultrasonic waves. While all of these are physical means of inactivating harmful organisms, they lack something chlorine and chlorine related compounds provide. These processes are good at the time of use but provide no long-term protection from regrowth.

## Non-chlorine Disinfectants

Chemicals such as iodine, bromine, various bases (alkaline chemicals), and ozone are good oxidizing agents, but each one has limitations when it comes to drinking water disinfection. Iodine has been used for years to disinfect cuts and skin abrasions and in low doses it can be used to disinfect drinking water. However, because of the high costs and potential physiological effects to pregnant women, it is not used in drinking water. Bromine is commonly used in swimming pools and spas, but because of safety related issues with handling the chemical it is not used in drinking water. An example of a base that can be used as a disinfectant is sodium hydroxide. It is also commonly used to disinfect cuts and skin abrasions, but it leaves a bitter taste if it is ingested and is not suitable for drinking water disinfection. Ozone is a great disinfectant for drinking water under certain instances. It is primarily used in the drinking water treatment process to

control taste and odor and to reduce the amount of total organic carbon prior to treatment. The main problem with ozone is it does not leave a residual, is difficult to store, and is expensive.

## Chlorine and Chlorine-Related Compounds

Chlorine has been used in the United States to disinfect drinking water for over 100 years. It does a great job at inactivating pathogenic organisms and leaves a residual preventing regrowth throughout the distribution system. In its natural state, chlorine is a gas with a greenish-yellow color. There are other chlorine related compounds such as calcium hypochlorite (solid) and sodium hypochlorite (liquid) commonly used to disinfect drinking water. In addition to chlorine and these related compounds, chlorine is often combined with ammonia to create chloramine. Chloramine is also an efficient disinfectant. One of the major drawbacks to using chlorine as a disinfectant is the potential creation of disinfection by-products such as total tri-halomethanes and halo-acetic acids

## Distribution System Water Quality

As water makes its way through the distribution system, distribution operators need to be able to maintain the quality of the water. Water quality can degrade within a distribution system for a number of reasons, including but not limited to age of water, temperature of water, lack of a disinfectant residual, pH, various reducing agents, and microorganisms. Maintaining a disinfectant residual within distribution systems is an important responsibility for distribution operators. Sampling, monitoring, and various maintenance activities can help with maintaining a disinfectant residual.

## Distribution Sampling

The SDWA states how many and where water quality samples need to be collected. In addition, state regulators such as DDW may also require additional sampling based on vulnerabilities and other water quality related issues.

All sources of supply must be sampled routinely for bacteriological, inorganic chemicals, organic chemicals, and radiological contaminants. Each group of contaminants and some individual contaminants have different sampling intervals and procedures. For example, VOCs are required to be sampled at each source annually unless there is a positive detection, in which case they need to be sampled quarterly.

Sampling within the distribution system is also required. However, there are far fewer constituents, which need to be sampled in distribution systems. The main contaminants which are required to be sampled for in distribution systems are bacteriological as part of the TCR and disinfection by-products. If you think about this, it makes sense. If you sample source water for VOCs for example, you would not need to sample for VOCs again in the distribution system. The reason for this is because VOCs do not develop in the distribution system. In contrast, in the absence of a disinfectant

residual, bacteria can regrow in a distribution system and disinfection by-products may form in a distribution system under certain conditions.

As part of the TCR, water utilities prepare sample siting plans. These plans identify the number of customers the utility serves, which in turn determines how many samples must be collected for total coliform bacteria. The sample locations and sampling frequency are also identified in these plans. Larger utilities can be required to sample dozens of locations on a weekly basis for total coliform bacteria as part of the TCR, while smaller utilities may just have to sample a few locations a month. At each location the disinfectant residual is also analyzed. This data can help determine if there is the potential for a problem within the distribution system. Let's take a look at a hypothetical example. Suppose ten locations per week are being sampled for total coliform bacteria and a chlorine disinfectant residual. Over three weeks, all the total coliform results come back negative (absent of total coliform bacteria), but the sampler has noticed a downward trend in the chlorine residual level at one of the sample locations. This sort of information can indicate a potential problem and maybe the next total coliform sample at this site will come back positive. This scenario doesn't necessarily mean something is wrong, but the sampler at least has data, which can be presented to other operators and may trigger some type of maintenance.

### Distribution System Maintenance

Maintaining an efficient distribution system can help maintain good water quality. Water entering a distribution system from a source is routinely disinfected with a chemical such as chlorine. While the water travels through the distribution system the disinfectant will do its job by inactivating pathogenic organisms. As this occurs, the amount of chlorine in the system (residual) will reduce. The further the water travels, the lower the residual level. The water also becomes older as it travels through the distribution system and the water can become stagnant, resulting in discoloration, odors, and low chlorine residuals. One way to help keep a disinfectant level at acceptable levels is to help move the water through the system by flushing dead ends and areas furthest away from sources. By flushing and helping to move water through the distribution system, the water and with it the disinfectant residual travels faster through the distribution system and the water does not become stagnant.



*Figure 3.5: Discolored water<sup>22</sup>*

Sometimes, residuals drop very rapidly or cannot be maintained within a distribution system. This typically occurs when the initial dose of the disinfectant is not high enough at the source water, the water stays in the distribution system too long because of low use, or there is some other problem within the distribution system. When this occurs, distribution operators may choose to add a disinfectant in water storage tanks. Since disinfectants are added at the sources of supply they are typically found at higher levels in the distribution system around these sources. Storage tanks are commonly placed on the outer edges of distribution systems and if water demands (usage) are low, disinfectant residuals can drop below acceptable levels. This is when distribution operators can add disinfectants, such as calcium hypochlorite granules or liquid sodium hypochlorite to storage tanks. This will help improve disinfectant residuals within the tank and then in the distribution system as water is taken out of the tanks during times of usage.

---

<sup>22</sup> [Image](#) by [Daniel Case](#) is licensed under [CC BY-SA 3.0](#)



Figure 3.6: Pipe repair<sup>23</sup>

## Water Quality Violations

When a water utility does not comply with drinking water quality regulations a violation occurs. Since many states (including California) have their own set of regulations, the states are the primacy agency for enforcing drinking water quality regulations. This means the enforcement comes from the state instead of the USEPA. However, since some regulations are specifically promulgated by the USEPA, they would be the primacy agency for those regulations.

Included in the SDWA is something referred to as the Public Notification Rule (PN). This rule ensures consumers will know if there is a problem with their drinking water. These notices are intended to alert customers if there is a risk to public health. Customers are notified when:

- the water does not meet drinking water standards;
- if the system fails to test its water;
- if the system has been granted a variance (use of less costly technology); or
- if the system has been granted an exemption (more time to comply with a new regulation).

If a water utility cannot meet a drinking water standard, that is they exceed an MCL for a contaminant, in addition to notifying their customers several things are commonly triggered:

- Resampling the water must occur. Depending on the contaminant, several resamples may be required.
- If these results confirm an MCL has been exceeded, then the source is usually taken out of service. There are some exceptions. Depending on the health effect,

---

<sup>23</sup> [Image](#) by [Barksdale Air Force Base](#) is in the public domain

the primacy agency may allow the source to be blended in order to bring the level of the contaminant below the MCL.

- Depending on the health effect of the contaminant, the utility may be required to notify the public immediately. Other times if the health risk is minimal, the utility would be required to notify their customers in an annual consumer confidence report.
- Depending on the level and the health effect of the contaminant, the utility may be required to install some form of treatment in order to remove or lower the level of the contaminant.

With some contaminants where a positive result occurs, but the level is below an MCL, additional monitoring is sometimes required. For example, nitrate has one of the more complex additional sampling requirements.



Figure 3.7: Sampling water<sup>24</sup>

### Nitrate Sampling Requirements

The SDWA states that nitrate must be sampled annually at each source entering the distribution system. If the result is more than half the MCL ( $>22.5$  mg/L as  $\text{NO}_3$  or  $>5$  mg/L as N) then quarterly sampling is required. Quarterly must continue until four consecutive quarters yield results less than half the MCL.

### Consumer Confidence Report (CCR)

The **CCR** is an annual report sent to all customers receiving water from a utility. This report provides information on the sources of supply, updates on new or emerging water quality regulations, health effects from contaminants found in their drinking

---

<sup>24</sup> [Image](#) by [Shaw Air Force Base](#) is in the public domain

water, levels for all contaminants found in the drinking water supply, and any violations which may have occurred. This CCR is very helpful in communicating to the public the safety of their water supply. The information within the report is from the prior calendar year and must be sent to all customers by July 1 of the following year. The report also must be provided in each language spoken within the utilities service area if the population speaking that language is greater than ten percent of the total population.



Figure 3.8: Sample CCR<sup>25</sup>



Figure 3.9: Sample CCR<sup>26</sup>

---

<sup>25</sup> Photo by [Tim Marshall](#) on [Unsplash](#) (modified by [COC OER](#))

<sup>26</sup> Photo by [rawpixel](#) on [Unsplash](#) (modified by [COC OER](#))

## Key Terms

- **Action Level (AL)** – action Levels are set for certain contaminants where an MCL does not exist and some type of response (action) is required by the water utility if an AL is exceeded
- **Consumer Confidence Report (CCR)** – an annual report sent to all customers receiving water from a utility
- **Detection Limit for Reporting (DLR)** – the Detection Limit for Reporting is set at a level that laboratories can accurately reproduce with the current method of analysis.
- **Maximum Contaminant Level (MCL)** – levels set as close to the MCLG as feasible
- **Maximum Contaminant Level Goal (MCLG)** – levels set at which no known or anticipated adverse health effects would occur
- **Public Health Goals (PHG)** – Public Health Goals are similar to MCLGs; California non-enforceable standards where an MCL does not exist



## Review Questions

1. Describe Total Coliform and its role in distribution drinking water monitoring.
2. What is the key difference between a primary and secondary drinking water standard? Name a couple of each and their associated affects.
3. Describe ways a water agency can reduce disinfection byproducts. What role does disinfection byproduct monitoring play in protecting public health?

## Sample Questions

1. What is a CCR?
  - a. Consumer Confidence Regulations
  - b. Customer Certification Requirements
  - c. Consumer Confidence Requirements
  - d. Consumer Confidence Report
  
2. Which are qualities of stagnant water in a distribution system?
  - a. discoloration
  - b. odor
  - c. low chlorine residual
  - d. all of the above
  
3. What is tri-halomethane considered?
  - a. surface water contaminants
  - b. by products of the disinfection process
  - c. groundwater contaminants
  - d. all of the above
  
4. What does AWWA stand for?
  - a. American Water Workers Agency
  - b. American Water Wage Association
  - c. American Water Works Association
  - d. None of the above
  
5. Which describes primary drinking water standards?
  - a. health-related
  - b. aesthetic-related
  - c. not enforceable
  - d. less important than secondary standards

# CHAPTER 4 – SYSTEM DESIGN

This chapter we will discuss how water systems are designed.

## OBJECTIVES

After reading this chapter, you should be able to:

- explain how source water availability and reliability effects distribution system design;
- describe the three main distribution system configurations;
- evaluate the main requirements, which affect the quantity of distribution system storage; and
- analyze and describe the main types of distribution system maps.

When designing a water distribution system, a lot of different things need to be considered. For example the following questions are some which might be considered;

- What will the water be used for?
- Is it a small rural farming community or a large industrial metropolitan city?
- Will the community grow in size?
- Are there other sources of supply available?

Planning is an important step in the design of a water distribution system. Most early communities were built around a water source, some place where water was available. This obviously made the planning and design much easier. However, as villages grew in to towns and as communities began to spread out well beyond the original sources of supply, planning and design became more difficult and more important. Below is a list of a few things that should be considered prior to or during the design of distribution systems.

1. **Water availability** – Is there an available supply of water to meet current and future demands?
2. **Source reliability** – How reliable is the source or sources of supplies? It is always better to have more than one source of supply.
3. **Water quality** – Does the current water quality meet regulatory standards?
4. **Location** – What is the location of the community in relation to the sources of supply? What is the topography of the community?
5. **Local, state and federal requirements** – In addition to water quality regulations, there are other local, state, and federal regulations.

Let's break down each one of these items in a little more detail.

### Water Availability

It is not by coincidence that early settlers and homesteads were in close proximity to rivers and lakes. These water bodies provided a source of fresh water for drinking and

bathing. In addition, it provided a good source of food. In addition to fish, other animals would gather around water sources. As communities began to grow, the availability of water became more and more important. In the late 1800s and early 1900s, Los Angeles relied mostly on local groundwater supplies. However, as the population began expanding rapidly, the need for another source of supply became evident. At the time, William Mulholland was the Los Angeles Water Company Superintendent and was instrumental in bringing water from the Owens Valley area in the north, making it available so Los Angeles could continue to expand.

Bringing water from the north to southern California required an extensive transmission pipeline system. Once the water reached Los Angeles, a distribution system network allowed for people to reside and spread out all across the area. A water transmission system is typically composed of large diameter pipelines bringing water to areas, which lack available water supplies. In contrast, a water distribution system disperses water throughout a given area through smaller diameter pipelines.

### Water Reliability

Accessing water from different sources and locations, such as in the case of Los Angeles, allowed for cities to grow at a rapid rate. In the early 1900s, William Mulholland realized the local groundwater serving the city of Los Angeles would not sustain the growing population and discovered another source of supply to the north. In this case, the Owens Valley not only provided an additional supply (availability) for Los Angeles, it also increased the supply reliability for the region. Multiple supplies of water increase the reliability. For example, if an area relies on a surface water supply as their main source and there is not enough precipitation one year to sustain the surface supply, a local groundwater system can supplement the demand.

In a distribution system having pipelines that interconnect, can provide a more reliable supply in the event of pipeline breaks or system failures. For example, a grid pipeline network (discussed later in this chapter) provides water service from multiple directions allowing water to be served to customers from more than one location. Having a reliable supply of water and a redundant system of pipelines is critical to an efficiently run water distribution system. In addition, having back up sources of power to operate pumps in the event of power outages also provides increased reliability.

### Water Quality

In addition to having an available and reliable supply of water, it is important to have a supply that meets water quality standards. A safe water supply is equally as important as any other consideration when designing a water distribution system. In instances where source water quality does not meet drinking water regulations, treatment can be implemented. However, if sources of supply are not in centralized locations, the cost of treatment can be prohibitive. For example, if a water utility has multiple drinking water groundwater wells and these wells are spread throughout the distribution system or

several miles, centralized treatment would be difficult. If each of these wells were contaminated, it might mean individual treatment systems would need to be installed at each location. The cost for individual treatment systems is typically more costly than a centralized treatment system. In contrast, if these wells are located within close proximity to each other, a centralized treatment system could be installed. This could significantly reduce the cost of treatment.

The cost of treatment is paid for by each customer through water rates. Therefore, in smaller communities any type of treatment could be costly causing devastating consequences for the residents. This is purely an “economy of scale” issue. For example, if the Los Angeles Department of Water and Power (LADWP) had to provide treatment on a groundwater well, the cost of this treatment would be spread out among their rate base (total number of paying customers). LADWP has hundreds of thousands of paying customers. However, if a small rural water utility with only a few hundred or even thousand customers needed the same type of treatment, it might end up being cost prohibitive.

## Location

The next area which needs to be considered is location. When it comes to real estate, the common mantra is “location, location, location”. Well this sort of speaks true to a water distribution system too. Location provides for water availability, reliability, and quality. This is not to say water cannot be brought in to areas where it does not naturally exist, but it does come at an additional cost. Water that is of good quality, readily available, and reliable will be considerably cheaper than if clean and reliable water needs to be imported over long distances.

Location also has to be considered when it comes to the actual design of a water system. For example, is the water distribution going to be built in an area, which is subject to freezing temperatures? If so, this will affect the depth of water distribution system infrastructure as well as above ground appurtenances such as fire hydrants. If a fire hydrant is filled with water and the ambient temperature is below freezing for long periods of time, the water within the hydrant can freeze rendering the hydrant inoperable. Topography will also affect system design. Are there wide ranges of elevation of the proposed water distribution system or is the topography relatively flat and uniform? If there is a wide variation in elevations, additional pumping might be required, as well as other appurtenances compared to an area where the terrain is flat. Other things which may affect distribution system design based on location are things like soil corrosivity and local geology. This can affect the types of material used for things such as piping as well as the installation process.

## Local, State, and Federal Requirements

Regulations will dictate minimum water quality and some system design standards and details. These standards and details can range from permitting the installation of

facilities to very specific drinking water quality regulations. Each state, county, and city can have different criteria which can affect the design and installation of a water distribution system.

At a minimum, all public water utilities must meet federal drinking water quality regulations. These regulations however, can vary from state to state. State drinking water quality regulations must be at least as strict as the federal standards, but they can be more stringent. An example of this is with the constituent chromium. There are several valance levels of chromium, with chromium VI being the most common. However, the federal Safe Drinking Water Act (SDWA) and the California (SDWA) have a maximum contaminant level (MCL) for “total” chromium. This is the maximum level of all valances of chromium allowed in drinking water. In the federal SDWA the MCL for total chromium is 100 microgram per liter (ug/L) and in California the level is 50 ug/L. This is an example where the state water quality regulation is more stringent than the federal requirement.

When it comes to design and installation criteria, there can be a number of local requirements, which include excavation permits, offset distances from other facilities, as well as other conditions. It is important for the design team to understand these requirements and help plan for them before and during the installation of distribution facilities.

In addition to these considerations when it comes to the design of a distribution system, there are a variety of other criteria which should be considered. Below is not an exhaustive list, but it covers various items which should also be considered.

- **Future growth** – In many areas, there are or will be plans for future growth. Some of these growth projections are understood through local planning documents, while other areas might not have as much detail. Regardless, it is always prudent to work with local agencies on the potential for future development plans and growth. This is particularly important when it comes to the sizing of facilities. For example, if a pipeline for an existing number of homes only needs to be six inches in diameter, but will need to supply many more homes in the future, it might be prudent to increase the size of the pipeline in anticipation of this future growth. This is also true for pumping and storage facilities. It is important for water utilities to understand the projected population growth of their area, understand the existing and future projected water demands, and what sort of fire protection requirements are needed for each type of customer class.
- **Cost and Funding** – Cost is another important item to consider when designing and building a new or expanding an existing distribution system. Who benefits from the work being done? Is the distribution system expansion for a new development or is it to improve the service for existing customers. Many times if

a new development is being planned, the owner (developer) of the property will be responsible for paying the costs associated with expanding the distribution system. However, the developer should also be responsible for paying some portion of the cost for the existing water system too. Why you might ask? Well, while the existing water system is benefitting the existing customers, a portion of the existing system will provide some benefit to the new development as well. Understanding this proportional cost is beyond the scope of this chapter and would be covered in more detail in a text related to water rates. However, it is important to understand that building a new distribution system or expanding an existing distribution system is quite costly and this cost needs to be shared by the customers receiving benefit. Sometimes a developer will pay for some or all of a distribution system project while other times the utility may carry debt to fund certain projects and then spread the cost to their customers over time.

### Distribution System Layout

Planning is an important step in designing the layout of a water distribution system. While all the items discussed above should be considered before and during the planning stages, there are other “nuts and bolts” related planning items in order to layout the design of a distribution system.

Distribution systems are commonly designed by the utilities engineering department while other times engineering consultants are used. Regardless of who the engineer is, planning the design layout is a critical step in any distribution system. Calculations need to be completed in order to properly size facilities, pipelines, and the various appurtenances of a distribution system. Some of the items which are considered are the following:

- Water demands
- Flow rates
- Flow velocity
- Fire flow requirements
- Topography
- Pressure
- Power requirements
- Material selection
- Land ownership

This is by no means an exhaustive list. However, it should provide some insight into things, which are considered when planning and designing a distribution system. These and other items help determine what materials are selected, the size of facilities needed, and how things are designed and ultimately installed.

While most of the planning and design of distribution systems is conducted in the office with professional engineers, distribution operators should also be consulted. Unfortunately, this step of discussing the planning and design of a distribution system with field operators is sometimes overlooked. Many times, the steps of planning and design happen without the input from the very people who will be installing and operating the systems being designed. It might seem obvious to consult distribution operators, but why then is it often overlooked? A lot of information is gathered during the planning and design phase. One of the more important things to review are plans called as-built drawings. An as-built drawing is simply that, it is a plan that is modified after it was installed and “as it was built”. Even after everything is considered during the planning and design stage, when the design plans make it to the field and the facilities are actually installed, things are often adjusted and changed during installation. These changes and adjustments are the result of conflicts that were not identified on the design plans and can end up costing significantly more than what was initially proposed. While the idea of being able to avoid all conflicts is not conceivable, consulting with field employees before the design plans are complete can help reduce some of these unforeseen conflicts.

## Distribution Design Configurations

One of the more important things behind the functionality of a distribution system is the layout or configuration. There are three common distribution system configurations. These are arterial loop, gird, and tree systems. Each one will be explained below. While some of these may be a more preferred and ideal installation configuration, sometimes less desirable designs cannot be avoided. The primary goals of a well-designed water distribution system is to provide good water quality at acceptable pressures to the utility’s customers. In order to meet these and other objectives such as meeting the required customer water demands, which include flows to fight fires and limiting the number of customers out of water during outages, the design of a water distribution system is extremely important.

### Arterial Loop System

The idea behind an **arterial loop system** is to provide flexibility by supplying water to the distribution system from multiple locations. This system attempts to surround the distribution system with larger diameter water mains. This provides adequate flows (volumes of water) to the interconnecting distribution system from different locations. Arterial mains are constructed on the perimeter of a distribution system bringing a main flow of water supply from various branches. An arterial loop system typically has very large diameter pipes (referred to as transmission mains) providing water to smaller but still large diameter mains (referred to as arterial mains), which then feed water to smaller mains (referred to as distribution mains), and finally these mains distribute water to the customers. See the example diagram below.



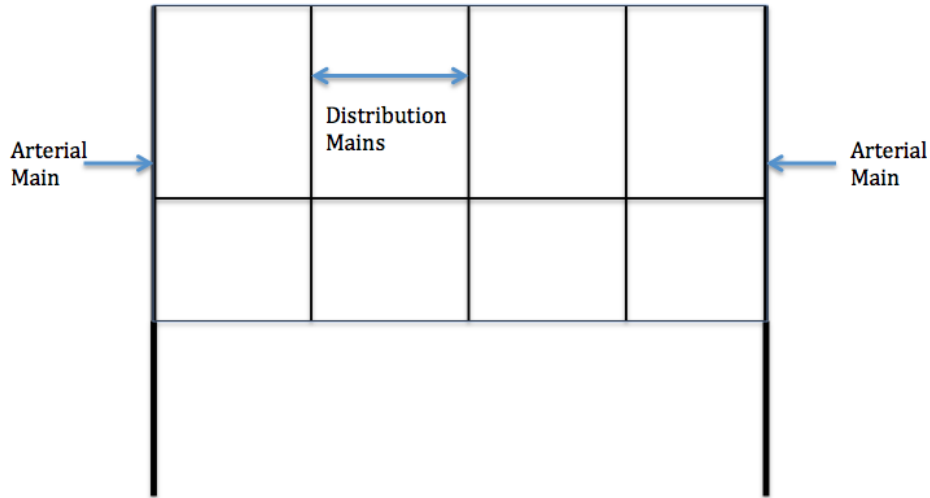

Figure 4.1: Arterial Loop Distribution System<sup>27</sup>

### Grid System

A **grid system** is one of the more desirable distribution system layouts. They can provide water to all customers from multiple areas. This configuration allows water to circulate throughout the entire system providing better water quality, pressures, and flow rates. Another positive benefit to a grid system is the ability to limit the number of customers who are out of water during outages from things such as water main breaks. The main difference between an arterial loop and a simple grid system is the grid system shown below is typically fed by a single transmission and/or arterial main.

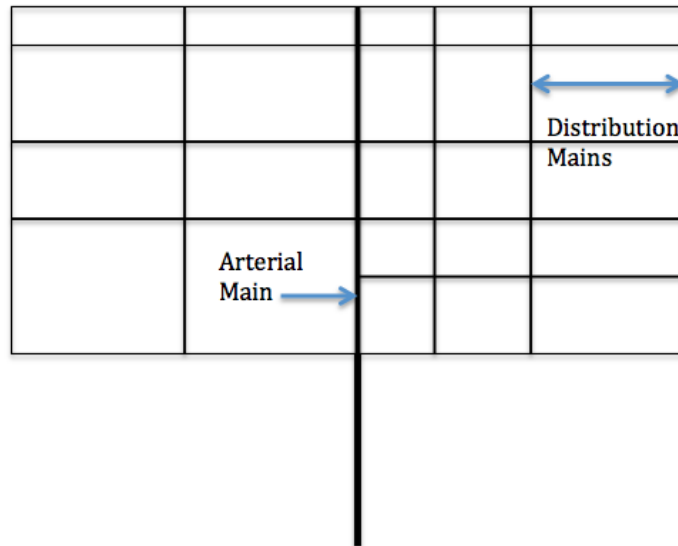

Figure 4.2: Grid system<sup>28</sup>

<sup>27</sup> Photo by Mike Alvord is licensed under [CC BY 4.0](https://creativecommons.org/licenses/by/4.0/)

<sup>28</sup> Photo by Mike Alvord is licensed under [CC BY 4.0](https://creativecommons.org/licenses/by/4.0/)

## Tree System

The **tree system** type of distribution system is the least desirable design. A tree system is typically fed by one larger main and then branches off to smaller distribution mains. However, as shown below, a tree system's distribution mains end in something referred to as "dead ends". Dead ends are where a water main terminates at the end of a cul-de-sac or other area where it cannot connect to another distribution main. Dead ends can result in reduced water quality, pressure, and flow. If a dead end distribution main is too large, the water in the main can become stagnant and cause undesirable taste, odor, and color water quality problems. Therefore, dead end water mains are sometimes undersized and then can result in reduced pressures and flows.

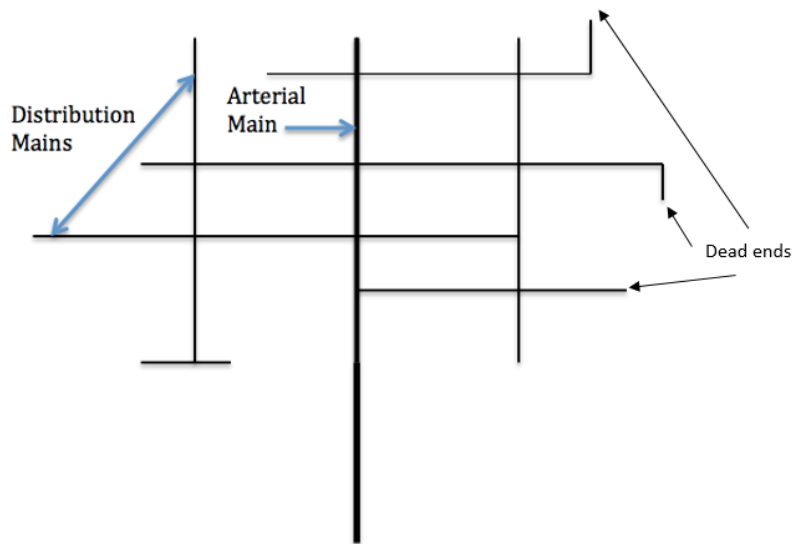

Figure 4.3: Tree system<sup>29</sup>

## Appurtenances

An **appurtenance** is a generic term for accessories associated with a functioning distribution system. In this chapter we will only focus on the last two appurtenances in the list below. Most of the others on the list below will be discussed in more detail later in this text.

- Valves
- Fire hydrants
- Elbow and angles
- Fittings
- Blow offs
- Air and vacuum valves (airvac)

In water distribution systems where there are high and low points (topographic elevation changes) blow offs and airvacs are commonly used. When you have low points

---

<sup>29</sup> Photo by Mike Alvord is licensed under [CC BY 4.0](https://creativecommons.org/licenses/by/4.0/)

in water pipelines, debris (sand, dirt) can accumulate at the bottom of the pipes. Also, as previously mentioned, water can become stagnant at the end of pipelines (dead ends). In these situations, blows are installed. Blow offs allow distribution system operators to flush water in order to remove any stagnant water or debris. In contrast, air can accumulate in high points of a pipeline. In order to remove air, air and vacuum valves are installed to automatically release air from the distribution system. Below are some examples of these appurtenances:



Figure 4.4: Fire hydrant repair<sup>30</sup>

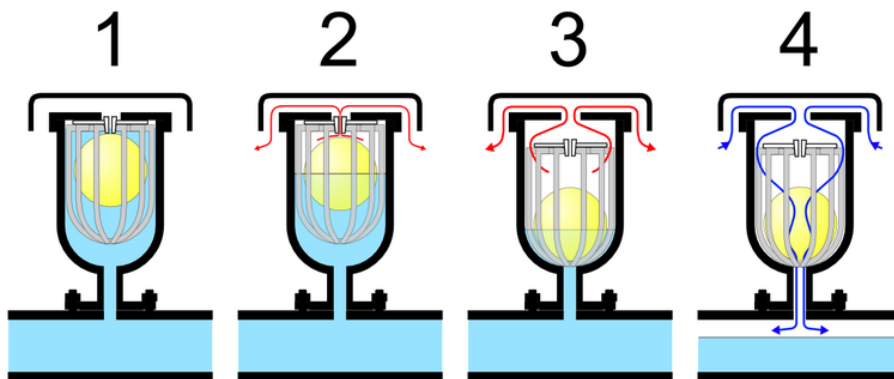

Figure 4.5: Air valve model<sup>31</sup>

<sup>30</sup> [Image](#) by the [Anderson Air Force Base](#) is in the public domain

<sup>31</sup> [Image](#) by Shigeru23 is licensed under [CC BY-SA 3.0](#)



Figure 4.6: Elbow pipe<sup>32</sup>



Figure 4.7: A Downtown Charlottesville fire hydrant<sup>33</sup>

## Water System Demands

As mentioned previously in this chapter, water demand is an important parameter, which is reviewed when planning and designing a water distribution system. Water demand includes a number of things including the demand of all customers within a distribution system (residential, commercial, industrial) and the demand to fight fires. It is important to identify not just the average demand of a distribution system, but also the maximum amount of water demanded on any given day and the peak demand

---

<sup>32</sup> [Image](#) by [Cschirp](#) is licensed under [CC BY-SA 3.0](#)

<sup>33</sup> [Photo](#) by [Ben Schumin](#) is licensed under [CC BY-SA 2.5](#)

during any given hour of the day. These three are critical in the design of a distribution system and are defined below.

- **Average Day Demand (ADD)** – The average day demand is the total distribution system water use over one year, which is then divided by 365 days. In the design of a new distribution system without any existing users, land use projections are commonly used to estimate the amount of water, which will be used by future users.
- **Maximum Day Demand (MDD)** – The maximum day demand is determined by looking at the entire demand over one year and determining the day with the highest (maximum) usage over one twenty-four hour period. Daily demands are typically calculated using production meters from supply facilities bringing water into a distribution system.
- **Peak Hour Demand (PHD)** – The peak hour demand is the highest water usage over a one hour period. This demand number can be measured by production meters, but can also be estimated through calculations.

### Fire Flow Demands

Residential, commercial, and industrial water demands are important for designing a distribution system. However, fire flows are a critical component especially when sizing storage and pumping facilities. Fire flows are commonly the determining factor when sizing water systems in smaller communities serving a population of less than 50,000 people. Fire flows are determined through a variety of fire and building code criteria determined by the Insurance Services Office (ISO). Local fire departments and organizations are typically responsible for providing this information and guidance to water utilities. Among other criteria, the ISO identifies minimum pipe diameters for specific uses, as well as pressure and flow requirements. Most areas have a requirement that pressures do not drop below twenty pounds per square inch (psi). The flow requirements will vary based on the type of use, such as schools, commercial buildings, and residential areas.

### Network Analysis

Engineers use a variety of tools when planning and designing a water system to determine the size of facilities, which will dictate the pressure, and velocity of the water flowing through the pipes. The pressure within a distribution system is determined primarily by the elevation of the storage facilities within the system. Pressure is commonly measured in pounds per square inch (psi). One pound per square inch equates to 2.31 feet of elevation, referred to as “head pressure”.

$$1 \text{ psi} = 2.31 \text{ ft}$$

**Example:** If a water storage tank sits one hundred feet above a water service, what is the subsequent pressure?

$$100 \text{ ft} \times \frac{1 \text{ psi}}{2.31 \text{ ft}} = 43.3 \text{ psi}$$

This pressure is a theoretical pressure in a water distribution system. As the water moves through pipes and the various appurtenances throughout a distribution system, the pressure is reduced due to friction. The roughness of the interior of the pipe, the diameter of the pipe, the changes in direction of the piping, and valves, all have an affect on the velocity and pressure of the flow of water. A standard calculation used by engineers to determine this head loss due to friction is the **Hazen-Williams equation or C-factor**. Another commonly used formula is the Darcy-Weisbach equation. These equations are beyond the scope of this text and beyond the necessary knowledge for distribution system operators to perform their jobs appropriately. Therefore, they are discussed in this chapter, but will not be used or explained beyond the general nature of their use by engineers. Since the Hazen-Williams equation is ideal for fluids such as water flowing at ordinary temperatures (40°to 75°F) it is the more commonly used formula. This equation is used to identify the smoothness (roughness) of the interior of a water main. The rougher the pipe interior, the more friction loss will be observed. This equation relates the flow of water in a pipe with the physical properties of the pipe and the pressure drop caused by friction. The resulting value is referred to as the C-Factor. The higher the C-Factor the smoother the pipe interior and the less head loss from friction. The lower the C-Factor, the rougher the pipe interior, which results in greater head loss from friction. The table below shows some typical pipe materials and corresponding C-Factors.

**Table 4.1: Examples of common distribution pipe materials and corresponding C-factors**

Material	Hazen-Williams C-Factor
Asbestos Cement	140
Cast-Iron 20 years old	89-100
Cast-Iron 40 years old	64-83
Steel	140-150
Ductile Iron (cement lined)	120
Ductile Iron	140
PVC (C900/905)	150

Another tool engineers use to determine the various parameters of a water distribution system is a hydraulic water model. Water models can help determine expected flows and pressures throughout a distribution system network and can sometimes accurately mirror what is occurring in the distribution system. While these models can be accurate in predicting pressures and flows, it is also helpful to calibrate these computer models with actual field data. Pressure recorders can be placed throughout a distribution

system on things such as fire hydrants to measure and record the pressure in a distribution system over a period of time. Some pumping equipment can also be equipped with devices to measure the pressure on the suction and discharge side of a pump.

Pressure is an important parameter to measure and monitor within a distribution system. Some systems can have excessive water pressures or very low pressures. This presents a problem for utility operators and customers alike. If pressures are too low, customers may not be able to operate things like irrigation sprinkler systems. If pressures are too high, things may prematurely fail due to the excessive pressure. Under normal flow conditions, acceptable pressures are commonly within the range of forty psi to one hundred fifty psi. However, at times certain areas within a distribution system, pressures can exceed even these relatively high values or drop below acceptable levels. Therefore, understanding what the pressures are going to be will dictate what types of materials (especially pipes) are acceptable. Pipeline strength is commonly expressed in terms of tensile and flexural strength. In addition to the internal loads expressed on pipes, there are also external loads such as traffic driving over pipes buried below ground or the amount pipe can bend or flex.

- **Tensile Strength** – This is the measure of the resistance a pipe has to the longitudinal or lengthwise pull it has before it will fail. When the flow of water changes direction within a distribution system network, it can put these types of forces against the pipe. Therefore the material chosen can be critical.
- **Flexural Strength** – This characteristic is the ability of a pipe to bend or flex without breaking. If the trench bedding (dirt) is not flat or if the pipe being installed needs to bend slightly as the road meanders left or right, different pipe materials have different abilities to bend or flex.

If a pipe does not have the adequate strength, then the possibility of a water pipe (main) break can occur. If the earth shifts during an earthquake for example, a pipe may rupture in what is referred to as a shear break. If a buried pipe is unevenly supported, a beam break may occur. In addition, if the internal pressures exceed the acceptable operating pressure of a pipeline, it may also rupture. Therefore, understanding the pressures within a distribution system and the appropriate materials to use under different circumstances is an important aspect of planning and design.



Figure 4.8: A pipe rupture in Los Angeles<sup>34</sup>



Figure 4.9: A pipe leak repair<sup>35</sup>

## Mapping (Plans)

Once all the planning is finished and the design criteria is selected, engineers get to work on creating design drawings (or plans) for the construction crews to use during the installation (construction) phase. These “construction plans” and accompanying specifications are not only important for the crews to properly build and install the distribution system facilities, they are also used in the budgeting (estimating) process. Once a set of plans are complete, contractors can provide bids or cost estimates. The estimates will include the cost for materials, labor, and equipment needed for construction.

---

<sup>34</sup> [Image](#) by [Los Angeles Fire Department](#) is licensed under [CC BY-ND 2.0](#)

<sup>35</sup> Image by Mike Alvord is licensed under [CC BY 4.0](#)



There are various types of plans for a distribution system. These typically include piping plans, pump station plans, source of supply plans (i.e., groundwater wells), and storage facility plans (above ground storage tanks). Each set of plans will have the pertinent information for constructing and the material needed. For example, a set of pump station plans will have all the required mechanical and electrical equipment needed. These plans will detail the facility housing this equipment. The facility might be as simple as a chain linked fence or as elaborate as a block walled building with a roof. Specifications will be detailed enough so the contractor performing the work will know what pumping equipment, valves, piping, motors, and any other items required to construct a full functioning pump station.

After facilities are constructed, plans are updated to reflect any changes that have occurred during the construction process. Even on the most thoroughly prepared design plans, things often change when they are actually constructed. Therefore, it is the responsibility of the construction contractor to make up the plans for the engineer to modify and update. These updated plans are referred to as as-built drawings. Once the as-built drawings have been prepared, they need to be provided to the distribution operators for future reference. These maps give the distribution operators information regarding all the existing facilities for locating and operating purposes. Each water utility will have their own standards and mapping styles, but typically, there are three main types of maps. These are comprehensive, sectional, and valve and hydrant maps.

- Comprehensive Maps outline the entire distribution system. They are useful in understanding the various pressure zones, general locations of pipelines and larger facilities, and commonly outline the entire service area boundary of the utility.
- Sectional Maps provide a more detailed picture of the distribution system on a larger scale. While these maps are similar to comprehensive maps, they have more details. For example, sectional maps will show distances between water main pipes and other buried utilities such as sewer and storm drain pipes. These maps help distribution operators identify which side of the street pipelines are located and provide the size and material as well.
- Valve and Hydrant Maps show the precise location of distribution system valves and fire hydrants. This information is extremely important so distribution operators can quickly identify which valves need to be isolated (closed) when there is a water main break. These maps are commonly used by distribution operators for valve and hydrant maintenance activities. Many times, the local fire department will request copies of these maps so they have a clearer understanding of fire hydrant locations.

The designing of a water distribution system is an important process in order for a water utility to be able to provide their customers with a reliable and high-quality supply of

water. Multiple departments are typically involved as well as outside consultants in order to properly plan, design, and construct a distribution system, which complies with all the required laws and regulations and operates in an efficient and functional manner.

#### Key Terms

- **appurtenances** – accessories in a functioning distribution system
- **arterial loop system** – a system that provides flexibility by supplying water to the distribution system from multiple locations; surrounding the distribution system with larger diameter water mains
- **Average Day Demand (ADD)** – the total distribution system water use over one year, which is then divided by 365 days. In the design of a new distribution system without any existing users, land use projections are commonly used to estimate the amount of water, which will be used by future users
- **flexural strength** – the ability of a pipe to bend or flex without breaking
- **grid system** - one of the more desirable distribution system layouts; provides water to all customers from multiple areas
- **Hazen-Williams equation or C-factor** - a standard calculation used by engineers to determine this head loss due to friction
- **Maximum Day Demand (MDD)** – determined by looking at the entire demand over one year and determining the day with the highest (maximum) usage over one twenty-four hour period
- **Peak Hour Demand (PHD)** – the highest water usage over a one hour period
- **tensile strength** – the measure of the resistance a pipe has to the longitudinal or lengthwise pull it has before it will fail
- **tree system** – the least desirable design typically fed by one larger main and then branches off to smaller distribution mains

## Review Questions

1. What is one of the most desirable of distribution layouts? Describe the layout. Why is it desirable?
2. What is a C-Factor and what role does it play in distribution system design?
3. How does aging infrastructure affect a water agency? What are some of the problems that agencies encounter with aging infrastructure?

## Sample Questions

1. Which of the following is the most desirable system configuration?
  - a. arterial loop
  - b. tree
  - c. grid
  - d. depends on the system
  
2. What results from dead ends?
  - a. restricted flow
  - b. stagnant water
  - c. water outages during breaks
  - d. all of the above
  
3. Where should blow offs be installed?
  - a. at high points
  - b. low points
  - c. regular intervals
  - d. only on large main lines
  
4. Where should air and vacuum valves be installed?
  - a. at high points
  - b. low points
  - c. regular intervals
  - d. only on large main lines
  
5. What does ISO stand for?
  - a. Insurance Services Organization
  - b. Insurance Services Office
  - c. Insurance Standards Organization
  - d. Insurance Standards Office

# CHAPTER 5 – WATER STORAGE

This chapter we will discuss the importance of water storage within distribution systems.

## OBJECTIVES

After reading this chapter, you should be able to:

- explain the uses and requirements of water storage;
- list the various types of water storage facilities;
- list water storage facility equipment; and
- describe the operations and maintenance of water storage facilities.

Water storage is an important component of a distribution system. The main purpose is to provide sufficient amounts of water to average or equalize the daily demands on the system. Storage provides increased operating conveniences by providing sources of supply throughout the day and at night when utility employees are not typically at work. It levels out pumping requirements, can decrease power costs from pumping, provides a supply of water during power outages, fire storage, and other benefits. This chapter of the text will examine water storage systems, the various types of water storage, how water storage effects water quality, and a general overview of the operation and maintenance of water storage structures.

## Why Water Storage is Needed

Water demand is highest in the early morning and evening hours of the day. In the morning customers are showering, using toilets, and preparing meals, which require water. In addition, most irrigation systems are in use in the early morning hours before temperatures get too hot. In the evening hours, people are returning from work and school and water demand typically increases during these times. There is low use midday and during overnight hours. Without storage, the pumping capacity would be approximately two times the average requirement. Adequate storage allows for uniform pumping. Storage also allows minimal operator involvement during non-working hours. Without storage, workers would need to be available to operate the system if unexpected increases in demand occur. A utility would require various different size pumps to match changes in demand. Frequent on-off cycling of pumps causes increased wear on pumps and motors and higher costs for electricity.

Another benefit of water storage is the ability to store and supply water during emergencies and power outages. If a water utility solely relied on pumps to meet demands, anytime there is a power outage, water service would be interrupted. Having water stored in tanks allows for uninterrupted service during these times. Some distribution systems have long transmission water mains bringing the water supply into the community being served. Under these circumstances, any repairs made to these pipes requiring the water main to be isolated, would disrupt water supply to customers.

Firefighting is another critical need of community water systems. Water utilities not only need to meet operational demands, they must also meet the demands to extinguish fires. Firefighting may account for as much as fifty (50) percent of total storage. In addition, fire-fighting demands must be met during main line breaks, power outages, and maximum customer demands. Adequate pressure must also be maintained during fire flows.

### Water Storage and Water Quality

Water storage can help with water quality and it can also contribute to water quality problems. As part of the Safe Drinking Water Act, a set of regulations called Surface Water Treatment Rule (SWTR), requires specific times that chlorine must be in contact with the water before the water reaches the first customer. Water storage tanks can provide detention time to allow the chlorine to remain in contact with the water long enough to provide the required time. Water storage can also be an area where blending multiple sources of supply can take place. If an impaired source of supply is pumped into a storage tank, unimpaired sources can also be pumped into the tank providing adequate blending of the impaired source.

Water quality can also degrade in water storage tanks. While water storage tanks provide various benefits, storing too much water can lead to water quality degradation. Chlorine residuals can diminish and water can become stagnant if the water within storage tanks is not changed. Cycling tanks (allowing the level in a tank to rise and fall) can help avoid stagnation and water quality degradation.

### What Type and Size of Storage is Needed?

Water storage tanks come in various sizes and styles. Some of the factors to determine the type and capacity of storage in a distribution system depend on the size of the system, the topography of the distribution system, and how the distribution system is laid out (is the system spread out or concentrated in a small area). These and other criteria are used to design the water storage needs. **Float on the system** is a method of operating a storage facility where daily flow into the system is approximately equal to average day demand. When customer demands are low, the storage facility will be filling and demands are high, the storage facility will be emptying.

System hydraulics are directly related to the location of water storage facilities within a distribution system. If a water storage tank is located in close proximity to a pumping station, the head loss (pressure) to the farthest portion of the distribution system may be excessive through normal size piping. Additional transmission mains can help alleviate this type of pressure loss. If a storage tank is placed at the farthest end of a service area adequate pressure is typically received at the far ends and near the pumping stations. This type of set up avoids the need for increased main sizes. However, there must be enough capacity to the remote location to refill the tank during off-peak periods. In addition, if there is a great separation between the pumping facility and

storage, lower pressures might occur in the middle of the distribution system. If possible, locating storage structures adjacent to the area with the lowest pressure is ideal. This typically provides enough available pressure to the entire service area and smaller diameter water mains can be used because flow from the tank is split into two directions.

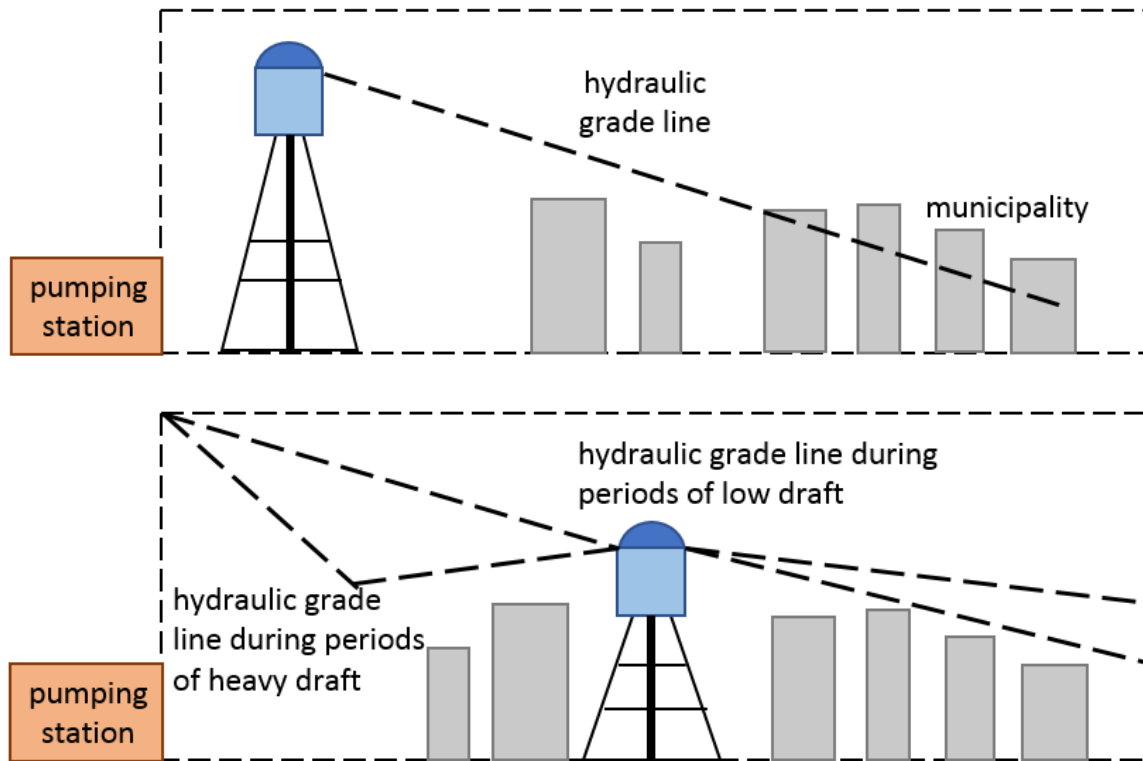

Figure 5.1: Hydraulic grade line diagram<sup>36</sup>

For hydraulic purposes, it is more ideal to have multiple smaller tanks instead of one larger tank. This allows for more stabilized and equal pressures throughout the distribution system. Head losses also increase whenever pumping is required over long distances and during peak demand conditions. Locating storage tanks near the center of a distribution system allows pumping stations to operate at or near average day demand conditions most of the time.

### Types of Water Storage Structures

There are various types of water storage facilities. They are made of different types of materials and are designed in different shapes to serve various needs. While there are various storage structures storing raw water and within a treatment plant, this section only discusses storage structures found in distribution systems. The following are some of the more common water storage facilities within a distribution system;

<sup>36</sup> Images by [COC OER](#) is licensed under [CC BY](#)

- **Elevated Storage Tanks** – In regions with relatively flat topography, elevated storage tanks are commonly used. They are above ground tanks supported by a steel or concrete tower or pedestal. Most are made of steel and designed to float on the system. If they are not constructed tall enough, they can overflow and provide inadequate pressures.



Figure 5.2: Elevated metal water tower<sup>37</sup>

- **Hydroneumatic Storage Tanks** – These tanks are used in very small systems with inadequate pressure. They are kept partially full with compressed air to provide water in excess of the pump capacity when required. These types of systems will also provide water for a limited time if a pump fails.
- **Standpipes** – These tanks are constructed directly on the ground and have a height greater than the diameter. They are commonly used to equalize storage near a source of supply like a well field. They can also be used to provide additional fire protection.

---

<sup>37</sup> [Image](#) by [McGhievers](#) is licensed under [CC BY-SA 4.0](#)





*Figure 5.3: A standpipe<sup>38</sup>*

- **Above Ground Storage Tanks** – These are the most commonly used forms of storage tanks along the west coast of the United States. They can store large quantities of water and are located where the topography is such that they can be constructed on hillsides. The main downside is that they require a fairly large area of land.



*Figure 5.4: An above ground storage tank<sup>39</sup>*

<sup>38</sup> [Image](#) by [Necraig](#) is licensed under [CC BY-SA 3.0](#)

<sup>39</sup> [Image](#) by the [U.S. Air Force](#) is in the public domain

## Components of Elevated and Above Ground Storage Tanks

These tanks have very similar components. This section will review the major components and address any differences between the two styles of storage structures.

### Inlet and Outlet Pipes

Elevated storage tanks generally have a common inlet and outlet pipe, while above ground storage tanks can have either common or separate inlet and outlet pipes. The purpose of these pipes is to bring water in and allow water to exit the tank. The purpose for having a separate inlet and outlet-piping configuration is to help water circulate inside the tank. The common pipe (called a riser) for an elevated storage tank typically runs up the middle of the support structure holding the tank. The inlet and outlet piping of an above ground storage tank typically enters the tank along the bottom portion of the tank. In the separate inlet/outlet configuration, the location of the inlet and outlet connection is typically at opposite ends of the tank.

### Overflow Pipe

Each type of tank is equipped with an overflow pipe. It is design to allow water to exit the tank to atmosphere in the event the water-level controls fail. They are commonly constructed to discharge into a catch basin and should never be directly connected to a sewer or storm drain. They should have a proper air gap separation from the area they are discharging into and should be screened or have a weighted flap to prevent animals from entering the pipe.

### Drain Connection

All tanks need to be inspected periodically. While some inspections can occur with water in the tank, it is common to drain a tank for inspection, cleaning, and repairs. Water in a tank can be lowered by preventing pumps from turning on to fill the tank. However, they can only be lowered to a level the height of the outlet pipe and at no time should a tank be drained completely while in service. Once the water is brought down as far as it can go while in service, a separate drain pipe can be opened to drain the rest of the water.

### Monitoring Devices

Water storage tanks, just like other water distribution facilities are commonly equipped with monitoring devices. Details about these monitoring devices are covered in another chapter. However, they will also be discussed here briefly. One of the most important things to monitor on storage tanks is the water level. Therefore, most are equipped with either a physical site gauge mounted on the outside of the tank and/or level sensors which can transmit tank levels to remote locations. These devices are commonly furnished with high and low water level alarms.

## Valves

In order to isolate a tank from the distribution system, a valve must be furnished along the inlet/outlet piping coming in to the tank. This valve can then be closed to take the tank out of service for maintenance and repairs. Sometimes a tank will be furnished with a valve referred to as an altitude valve. This valve is designed to close preventing the tank from overflowing.

## Vents

Air ventilation is usually provided at the tops of tanks to allow air to escape as the tank is filling and air to enter and the level in the tank drops. These air vents must be large enough to prevent the tank from collapsing and they must be properly screened with a minimum mesh size of  $\frac{1}{4}$ " ,

## Access Hatches

Access inside a tank also needs to be provided. There are at least and sometimes multiple access hatches on the top of storage tanks. These allow works to enter the tank for inspection and maintenance. These hatches must be properly constructed with rims under the cover to prevent surface water runoff from getting into the tank. There are also manways at the bottom of the tank for access when a tank has been drained and taken out of service for maintenance and inspection.

## Ladders

Access needs to be provided to the tops of tanks and inside tanks. Ladders usually provide this access. Some above ground water storage tanks use spiral staircases as opposed to ladders. Elevated storage tanks are usually equipped with three (3) different ladders. The first one runs up the leg of the tower from the ground to the balcony around the tank. The second ladder runs from the balcony to the top of the tank roof. The third ladder runs along the inside of the tank for inside access. Outside ladders should be installed six (6) to eight (8) feet off the ground or have a locked metal shield around the bottom to prevent unauthorized access.

## Cathodic Protection

Interior tank walls are subject to corrosion, especially in the upper portions, which are not constantly submerged in water. Cathodic protection can reduce this interior corrosion in coated steel tanks. Cathodic protection reverse the flow of current that tends to dissolve iron from the tank surface causing rust and corrosion. Electrodes with a direct current (DC) are used and will corrode instead of the tank walls. In warm climates, the electrodes can be suspended from the tank roof. In cold climates, the electrodes must be submerged. The anodes can last up to ten (10) years, but should also be inspected annually.

## Tank Coatings

Since steel can oxidize and deteriorate and since water is considered the “universal solvent”, it is important to properly coat the interior and exterior of tanks. Interior coatings must be able to withstand constant emersion in water, varying water temperatures, alternate wetting and drying periods, ice abrasion, high humidity, heat, chlorine, and mineral content in the water. Exterior coatings must endure similar conditions and maintain a good appearance. All interior coatings must be NSF approved.

## Operation and Maintenance

The American Water Works Association recommends that all water storage structures be completely inspected every three (3) to five (5) years. Elevated and above ground storage tanks should be periodically drained, cleaned, inspected, repaired, and painted. The interior surfaces should be cleaned thoroughly with a high pressure water jet or by sweeping and scrubbing. All dirt and debris should be removed from the tank and a complete or spot re-coating should also occur.

All tanks need to be disinfected before being placed in service. This includes new construction and tanks taken out of service for maintenance. There are three (3) basic methods for disinfecting storage tanks.

1. The first method involves filling the entire tank with water and held at a disinfectant residual level of 10 mg/L. If the water is disinfected before entering the tank the detention time is six (6) hours and if the tank is filled and then disinfected, the detention time is twenty-four (24) hours.
2. The second method involves spraying the interior walls with a disinfectant solution concentration of 200 mg/L.
3. The third method requires six (6) percent of the tank to be filled and disinfected to a residual of 50 mg/L. The tank is then completely filled and held for twenty-four (24) hours.

The tank must then be sampled and analyzed for total coliform bacteria. If the results come back positive, additional disinfection is required until two (2) consecutive samples are negative. New and recoated tanks must also be sampled and analyzed for volatile organic compounds.

Routine inspections should also be conducted at water storage tanks. The overflow piping, vents, hatches, ladders, and locks should be monitored frequently for damage and vandalism. Ladders should be in good condition and replaced if deemed unsafe. The roof and access points should also be checked for cracks and holes to prevent surface water leaking into the tank.

### Key Terms

- **float on the system** – a method of operating a storage facility where daily flow into the system is approximately equal to average day demand; when customer demands are low, the storage facility will fill and when demands are high, the storage facility will empty

## Review Questions

1. Name the types of water storage structures.
2. Why is floating on the system an integral component of a water storage structure? What are the benefits that come from floating on the system?
3. What is done to protect steel water storage structures from corrosion?

## Sample Questions

1. What is an altitude valve used for?
  - a. to prevent storage tanks from filling too fast
  - b. to prevent storage tanks from overflowing
  - c. to separate the inlet and outlet flows
  - d. None of the above
  
2. How frequently should water storage reservoirs be completely inspected?
  - a. every year
  - b. every other year
  - c. every 3 to 5 years
  - d. every 5 to 10 years
  
3. Without storage, how much should pumping capacity be approximately?
  - a. twice the average requirement
  - b. three times the average requirement
  - c. less than the average requirement
  - d. none of the above
  
4. What percent can fire demand account for?
  - a. 10% of storage
  - b. 25% of storage
  - c. 50% of storage
  - d. 100% of storage
  
5. Which is a recommendation for storage tanks?
  - a. separate inlet and outlet piping
  - b. common inlet and outlet piping
  - c. outlets twice as large as inlet piping
  - d. there are no recommendations

# CHAPTER 6 – PIPELINES

This chapter we will discuss the pipes used to distribute water.

## OBJECTIVES

After reading this chapter, you should be able to:

- describe the different pipe materials and sizes;
- explain hydraulics and how water moves through pipes; and
- identify the causes and results from water hammer and tuberculation.

Throughout the history of water distribution, a critical component of getting water from the source to the customer is pipelines. Pipelines within a distribution system can be separated into three main categories:

- transmission piping
- distribution piping
- service piping

These three categories have very distinct characteristics and uses.

### Transmission Piping

Transmission water mains (piping) are the largest in diameter of the three. They can range from as small as 16" in diameter up to more than 120" in diameter depending on the size of the distribution system, the location of the source water, and the number of customers within the distribution system service area. Smaller utilities with the sources of supply relatively close to the distribution system would have the smaller diameter pipes while larger utilities with the source water further from the distribution system would have larger diameter transmission mains. Transmission water mains convey large volumes of water from the source to areas within the main distribution system. They are commonly installed without any other connections to the pipe until it reaches the distribution system. However, in smaller distribution systems there can be additional pipes connected to a transmission main and there may even be service connections. Below is an example of a transmission water main.



Figure 6.1: A transmission water main<sup>40</sup>

<sup>40</sup> [Image](#) by [James T M Towill](#) is licensed under [CC BY-SA 2.0](#)



## Distribution Piping

Distribution system piping is simply that, piping that distributes water throughout the distribution system. Diameters of distribution system piping range from as small as 4" up to 24" and sometimes larger. The most common sizes of distribution system water mains are 8" – 12". Distribution mains connect to transmission mains as these pipes enter a distribution system. These water mains branch off into roads within communities to bring water supplies to customers.

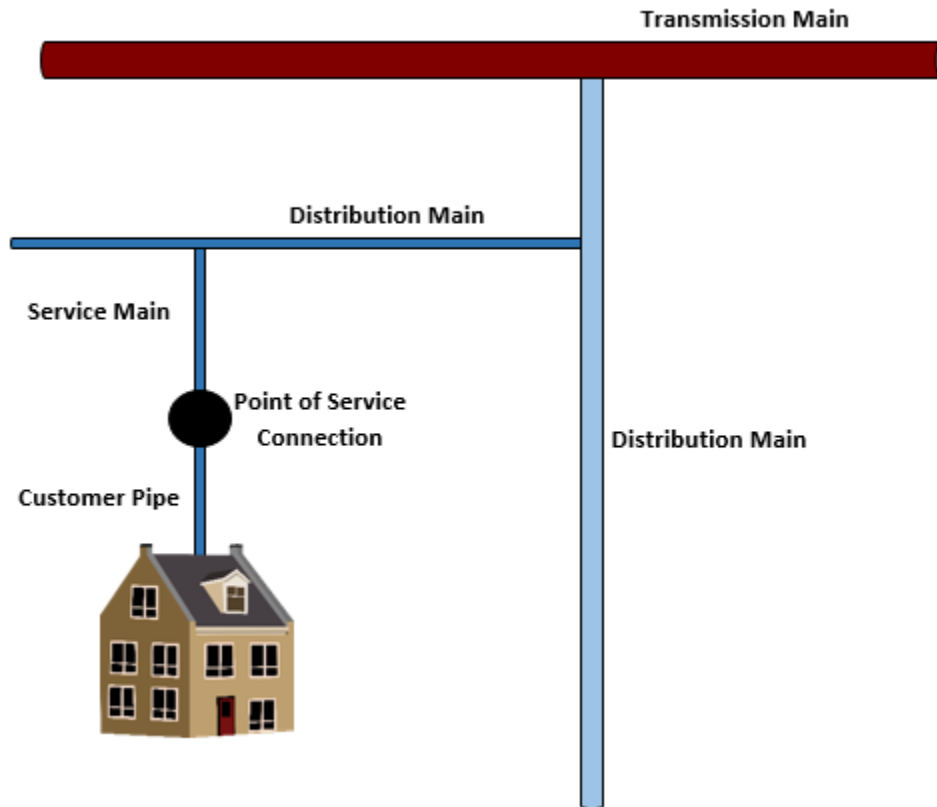

Figure 6.2: Water distribution piping<sup>41</sup>

## Service Main

In order to get water from the distribution main to a customer, a service main (lateral) is attached to the distribution main. In the diagram above, you can see this pipe between the distribution main and a black dot. The black dot represents the water meter or point of connection between the water utilities infrastructure and the customer's piping. Service laterals typically range in size from 1" to 10" in diameter. Most single family residential service laterals are 1" to 2" in diameter, while larger commercial services can range in size up to 10" in diameter and sometimes even larger. The size of a service lateral is dependent on the amount of water use from the customer.

<sup>41</sup> [Image](#) of house by [rdevries](#) is licensed under [CC0 1.0](#) (modified by [COC OER](#))

## Pipe Selection

There are a number of things, which dictate the type of pipe material a utility would select. As discussed above, the use is something utilities look at to determine the material to use. Other things include resistance to corrosion, interior smoothness, cost, ease of use, strength, and local conditions (i.e., soil type).

## Pipeline Materials

There are various materials used for water mains. In the 1800s up to the early 1900s, **wooden water mains** were used. Wood was a usable material because hollowed out wooden logs did not expand like metal pipes and the thickness provided insulation properties. However, as distribution systems became more sophisticated and pressures increased, wooden pipes were replaced with grey cast-iron pipes.

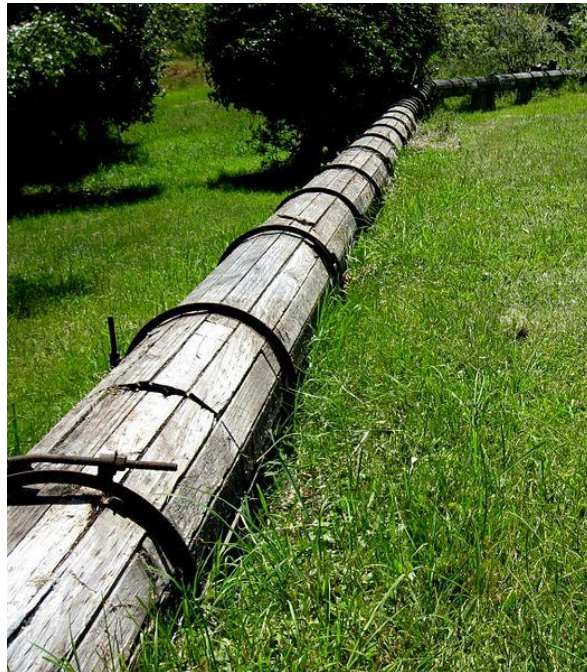

*Figure 6.3: An old-fashioned wooden water main<sup>42</sup>*

**Grey cast-iron pipe (CIP)** was easier to manufacture. They were strong and provided a long service life. One of the main drawbacks to this pipe was its brittleness. If the pipe wasn't handled carefully, it would easily crack. Another major drawback was the lead poured joints. In order to properly connect sections of the pipe together a molten lead joint was poured around each connection point.

---

<sup>42</sup> [Image](#) by John Newcomb is licensed under [CC BY 3.0](#)



Figure 6.4: An example of a grey cast-iron pipeline<sup>43</sup>

## Ductile Iron Pipe

In the early 1970s, manufacturing plants moved away from CIP and started manufacturing ductile-iron pipe (DIP), which is even stronger than CIP, more versatile, not brittle, and does not use any lead. The only drawback to DIP is the susceptibility to corrosion from aggressive waters and soil. In order to protect the inside of DIP from corroding, they are commonly lined with cement mortar. If soils are corrosive, DIP is usually wrapped in plastic bags. The images below show examples of cement mortar lined (CML) DIP and DIP that has been “bagged” before installation. DIP typically comes in diameters of 4” – 64” and usually in lengths of 18’ – 20’. The pressure range for DIP is 150 psi to 350 psi.



Figure 6.5: A ductile iron pipe<sup>44</sup>

<sup>43</sup> [Image](#) by [Andrew Curtis](#) is licensed under [CC BY-SA 2.0](#)

<sup>44</sup> [Image](#) by [Yeti Hunter](#) is licensed under [CC BY-SA 4.0](#)



Figure 6.6: The maintenance of a ductile iron pipe<sup>45</sup>

## Steel Pipe

Steel pipe has been used for well over a century. In the mid-1800s when water pressures were high, steel pipe was commonly manufactured for use. While steel pipe can be manufactured to small diameters (4”), the more common use of steel pipe is when large diameters are needed. Diameters of steel pipe ranges up to 120” and even larger if needed. Steel pipe is lighter in weight than CIP and DIP and can be fabricated for special needs. Some of the main disadvantages to steel pipe is both internal and external corrosion and the potential for a partial vacuum to collapse the pipe.



Figure 6.7: Steel pipe maintenance<sup>46</sup>

<sup>45</sup> [Image](#) by [Frankemann](#) is licensed under [CC BY-SA 4.0](#)

<sup>46</sup> [Image](#) by [Mike Alvord](#) is licensed under [CC BY 4.0](#)

## Asbestos-Cement Pipe

**Asbestos-Cement Pipe (ACP)** was first introduced in the US around 1930. It was commonly used in areas where metallic pipe was subject to corrosion. Pressure classes are not typically as high as pipe made from metal, but they come in pressure ranges up to 200 psi. ACP only comes in diameters ranging from 4" to 42" and the lengths (10' – 13') are shorter than their DIP counterpart. ACP is not subjected to aggressive waters as metal pipe, it is fairly light weight and has a relatively smooth interior surface. It is fairly brittle and can crack if not properly handled. Special safety precautions must be taken in order to prevent employees from being exposed to asbestos fibers.



Figure 6.8: A brittle Asbestos-cement pipe<sup>47</sup>

## Polyvinyl Chloride Pipe

Polyvinyl chloride pipe (PVC) were first introduced around 1940. The durability, resistance to corrosion, lightweight, and cost effectiveness soon became very attractive in the waterworks industry. Because these pipes are made with vinyl chloride, they must be tested and meet certain criteria to ensure no harmful chemicals leach out. In some instances, PVC pipe can also cause taste and odor problems. Another desirable characteristic of PVC piping is the flexibility. When using PVC piping, special care must be taken when storing for long periods of time since plastic is susceptible and can become damaged from ultra-violet light.



Figure 6.9: Polyvinyl chloride (PVC) pipes<sup>48</sup>

<sup>47</sup> [Image](#) by [DDanielsson](#) and [Wayne Eddy](#) is licensed under [CC BY-SA 3.0](#)

<sup>48</sup> [Image](#) by [Pam Broviak](#) is licensed under [CC BY-SA 2.0](#)

The materials that we have discussed are primarily used for transmission and distribution piping. The material used for service laterals are commonly made of either copper or PVC. However, in years past, galvanized pipes were also used. Copper is malleable and resistant to corrosion, which makes it a perfect material for piping between a distribution main and the point of connection to a customer. PVC is also used with the preferred type of PVC being polybutylene since it is not as ridged as schedule 40 or schedule 80. This table summarizes the types of pipes and their C-factor or resistivity to flow from friction. Wooden pipes are not included, because they are not a modern choice in distribution systems.

**Table 6.1: Pipe Material Type Benefits and Drawbacks**

Material	Benefits	Drawbacks	C-Factor <sup>49</sup>
grey cast-iron pipe (CIP)	easy to manufacture; strong; long service life	brittle; lead poured joints	100-130
ductile-iron pipe	stronger than CIP; not brittle; does not use lead	vulnerable to corrosion	140
steel pipe	lighter than CIP and CIP; can be fabricated for special needs	vulnerable to corrosion; partial vacuum can collapse the pipe	90-150
asbestos-cement pipe (No longer available)	less vulnerable to corrosion; lightweight; smooth interior	brittle; comes in limited lengths; requires safety protocols for handling	140
polyvinyl chloride pipe (PVC)/high density polyethylene (HDPE)	durable; resistant to corrosion; lightweight; cost-effective; flexible	permeable to petroleum products; may cause taste and odor problems	150

### Pipeline Connections

Water mains are generally connected with either mechanical or push-on joints and sometimes flanged connections. The type of connection is determined by the installation. For example, above ground pipeline installations, such as in pump stations, **flanged connections** are very common. A flanged connection provides a strong and ridged connection and allows for easy disassembly if a section of pipe or other appurtenance needs to be removed. Flanged connections are not as common in

<sup>49</sup> C-values are sourced from [The Engineering Toolbox](#)

underground installations, primarily because of the exposed nuts and bolts of flanged fittings. Pipes connected with **push-on joints** are manufactured in a “bell” and “spigot” style. The bell end is a wider flared end and the spigot is narrower and tapered. See the example below:



Figure 6.10: Polyvinyl chloride pipe with spigot and bell ends<sup>50</sup>



Figure 6.11: Stacked PVC pipes<sup>51</sup>

The bell end has a gasket inside and the spigot end is “pushed” on to make the connection. Both ends of the pipe must be thoroughly cleaned and lubricated before making the connection. One of the main problems with push on joints is the possibility of the joints separating under certain conditions. In addition, on slopes, push on joints

<sup>50</sup> [Image](#) is in the public domain

<sup>51</sup> [Image](#) by [Dwight Burdette](#) is licensed under [CC BY 3.0](#)

must be installed with the bell end facing up hill. This will prevent the spigot end from sliding out of the bell. In some instances where additional support is needed, there are certain restraints that can be used. These types of connections are typically less expensive than other connections and are easier to install.

A **restrained joint** is a type of pipe fitting (joint), which uses lugs, bolts, and gaskets to prevent longitudinal (back and forth) movement between pipes. **Mechanical joints** are a restrained type of pipe fitting (joint), which still allows for some longitudinal and latitudinal (side to side) movement (deflection) between pipes. Flanged connections are also used to connect pipes and fittings together. Flanged connections are typically limited to above ground installations because of the potential of corrosion and dirt filling in around the bolts.

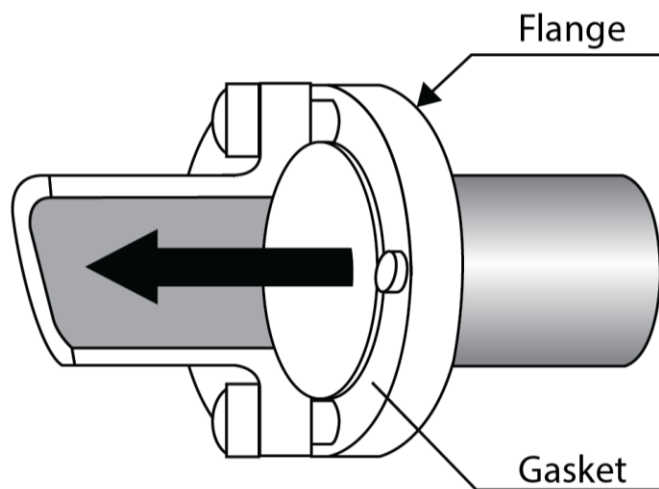

Figure 6.12: A flanged fitting<sup>52</sup>



Figure 6.13: An exposed water main joint<sup>53</sup>

<sup>52</sup> [Image](#) of Flanged fitting by [Mysid](#) is in the public domain

<sup>53</sup> Image by [Ian Capper](#) is licensed under this [CC BY-SA 2.0](#)





Figure 6.14: An exposed flanged joint<sup>54</sup>

Mechanical joints are similar to push-on joints. However, they have a means to “lock” the pipe and fittings together. Restrained joints are used with push-on fittings and require some type of restraining system. Below is an example of one such restraining system, mega lug rods. Tie rods are another type of restraining system. These help to hold two sticks of pipe together.



Figure 6.15: Mega lug rods<sup>55</sup>

<sup>54</sup> [Image](#) by [Brandonrush](#) is licensed under [CC BY-SA 4.0](#)

<sup>55</sup> [Image](#) by [Markus Schweiss](#) is licensed under [CC BY-SA 3.0](#)



Figure 6.16: A mega lug is being prepared as a temporary valve to close off the end of a broken water pipe in order to restore water to the Blatchford-Preston Complex<sup>56</sup>

#### Key Terms

- **asbestos-cement pipe (ACP)** – pipe that was first introduced in the US around 1930; was commonly used in areas where metallic pipe was subject to corrosion
- **flanged connection** – provides a strong and ridged connection and allows for easy disassembly if a section of pipe or other appurtenance needs to be removed; not as common in underground installations, primarily because of the exposed nuts and bolts of flanged fittings
- **grey cast-iron pipe (CIP)** – pipe that is strong and provided a long service life as well as easier to manufacture; one of the main drawbacks to this pipe was its brittleness
- **mechanical joints** – a restrained type of pipe fitting (joint), which still allows for some longitudinal and latitudinal (side to side) movement (deflection) between pipes. Flanged connections are also used to connect pipes and fittings together
- **polyvinyl chloride pipe** – pipe first introduced around 1940; the durability, resistance to corrosion, lightweight, and cost effectiveness soon became very attractive in the waterworks industry
- **push-on joints** – connections manufactured in a “bell” and “spigot” style
- **restrained joint** - a type of pipe fitting (joint), which uses lugs, bolts, and gaskets to prevent longitudinal (back and forth) movement between pipes
- **wooden water mains** – pipe that is hollowed out wooden logs did not expand like metal pipes and the thickness provided insulation properties

---

<sup>56</sup> [Image](#) by Tech. Sgt. Michael Boquette of the [U.S. Air Force](#) is in the public domain

## Review Questions

1. Describe the pathway water takes from source to customer in regard to different pipes. What are some of the materials used for each of these types of pipes?
2. What type of pipe might an agency use if they needed a large diameter transmission line? What type of pipe would be preferred for its flexural strength?
3. How does pipe material selection have long term effects for a water agency? What pipe material and pipe joints would you choose for areas prone to earthquakes?

## Sample Questions

1. Where are flanged pipeline connections very common?
  - a. in below ground installations
  - b. only for sewer systems
  - c. in above ground installations
  - d. none of the above
  
2. What lengths do asbestos-cement pipe come in?
  - a. longer than DIP
  - b. shorter than DIP
  - c. the same as DIP
  - d. all of the above
  
3. What is the function of transmission mains?
  - a. to deliver water directly to customers
  - b. to carry water to treatment plants
  - c. to transport large volumes of water
  - d. to convey irrigation water
  
4. Which of the following would be a correct order for how water gets to a customer?
  - a. source, distribution main, transmission main, service lateral
  - b. service lateral, distribution main, transmission main, source
  - c. source, transmission main, service lateral, distribution main
  - d. source, transmission main, distribution main, service lateral
  
5. Which of the following pipe material is most susceptible to collapse from partial vacuum?
  - a. steel
  - b. DIP
  - c. plastic
  - d. concrete

# CHAPTER 7 – VALVES

This chapter we will examine water distribution valves and why they are used.

## OBJECTIVES

After reading this chapter, you should be able to:

- describe the different types of valves;
- explain why different valves are used with different applications; and
- identify the operational and maintenance criteria for valves.

Water valves are an important part to any water system. The main purpose of a valve is to stop and isolate the flow of water. There are many different types of valves and the uses vary, but the primary purpose is to stop the flow of water. However, as you will see in this chapter, valves serve a variety of purposes.

Valves are used to stop and start the flow of water. When a pipe breaks, in order to stop the flow of water a valve is commonly closed. This prevents the water from flowing and allows for utility operators to repair the pipe. Once the repair is finished, the valve is opened and water is allowed to flow once again.

Some valves are used to regulate pressure or throttle flow. Sometimes the water pressure is too great and can pose a problem and damage pipes or other equipment. Residential homes commonly use pressure regulating valves in order to reduce the pressure before the water enters a home. These types of valves can also be used within a utilities distribution system. Throttling flow is sometimes needed in order to reduce the amount of water passing through pipes.

Certain valves are used to allow the flow of water in one direction only. These valves prevent the flow of water in the opposite direction. A common type of valve is a check or backflow preventer. These valves are unidirectional valves and allow the water to flow in one direction only.

Other valves are designed to relieve pressure. When water pressure builds up and gets to a point where the pipes or other appurtenances can get damage, a pressure relief valve can be used to allow the water to flow out of the system and relieve the high pressure.

## Types of Valves

There are a number of different types of valves in the water industry for the various uses describe above. The following list of valves is not an exhaustive list, but it is a very comprehensive list of valves used in the water industry.

- Gate
- Pinch
- Needle
- Globe
- Diaphragm
- Plug

- Ball
- Butterfly
- Check
- Relief
- Control

Each one of these valves has specific uses and some of these valves are more commonly used than others. Understanding the various uses and types of valves is important for understanding how water distribution systems function. For example, there are several types of valves commonly used in water mains in order to stop the flow of water, but a certain type (butterfly) is not suitable for a maintenance function referred to as “pigging”.

**Pigging** is a process to clean the inside of a water main. “Pigs” are made from various materials, but are commonly made of foam of various densities and are pushed through a water main. If a water utility uses butterfly valves then this type of cleaning process is not possible because the valve would be an obstruction. Other types of valves can be used at pump stations, wells, or other locations within a water distribution system.

Each valve will be discussed in detail throughout this text. However, it is important to understand the four primary functions of valves within a distribution system.

- **Starting and Stopping Flow** – In order to change the direction of the flow of water, stop the flow of water, and then start the flow of water, certain valves are used. When a water pipe breaks, a valve is used to stop the flow of water and isolate the leak so it can be repaired. Once the repair is made, the valve will be opened to start the flow of water once again. Some examples of these valves in a distribution system are distribution system isolation valves, fire hydrant auxiliary valves, pump control valves, and water service valves.
- **Regulate Pressure and Throttle Flow** – Certain valves are used to lower the pressure if it is too high or to reduce the flow of water by throttling the flow. Only specific valves should be used for these purposes because some valves can get damaged if used for the incorrect purpose. An example of a pressure regulating valves within a distribution system is one installed between two different pressure zones. One zone is higher than the other and these types of valves can be installed to reduce the higher pressure and release water when needed to the lower pressure area.
- **Prevent Backflow** – To prevent water from flowing in the wrong direction certain valves can be used to prevent something referred to as backflow. Backflow prevention is needed when a potable water supply is connected to a non-potable water supply. There are five (5) main methods and devices used for preventing backflow. These will be discussed later in this chapter.
- **Relieve Pressure** – When pressure is too high within a water system, sometimes the pressure needs to be relieved to prevent a rupture of the system. Pressure relief valves are common in various installations. Air and vacuum valves are an example of a pressure

relief valve within a distribution system. These valves allow air to escape preventing sudden rupture of a pipe.

### What differentiates the various types of valves?

Valves can be classified by how they regulate the flow of water. There are four (4) main types of how a valve operates.

- **Closing Down** – Globe and Piston valves close down in order to stop the flow of water.

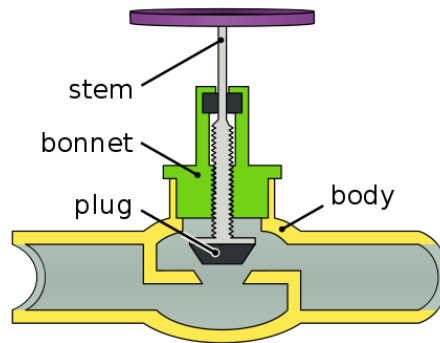

Figure 7.1: A globe valve diagram<sup>57</sup>

A globe valve is commonly found on outside residential faucets, also referred to as a sill cock. The “plug” end of a globe valve closes down into a valve port, which shuts off the flow of water. The distance between fully open and fully closed is relatively short.

A piston valve is similar to a globe valve. It is equipped with a piston shaped closure member, which intrudes into a seat bore to stop the flow of water. Piston valves are commonly used on control valves.

These types of valves are susceptible to sediment being trapped on the seat preventing the valve to close down completely. There is also some amount of flow resistance with these types of valves, especially a piston valve.

- **Sliding** – Gate valves are the most common valve found in distribution systems. They are classified as a sliding down style. A hand wheel or a key lowers a “gate” down on a seat. The face of the gate can become worn or objects can get lodged under the gate preventing a tight or complete seal. These types of valves should not be used to throttle flows as the gate can become damaged from the force of the flow of water. There are several different types of gate valves and they will be discussed later in this chapter. The image below is an above ground type of gate valve with a hand wheel attached to the operating nut for opening and closing.

<sup>57</sup> Image by [Petteri Aimonen](#) is in the public domain

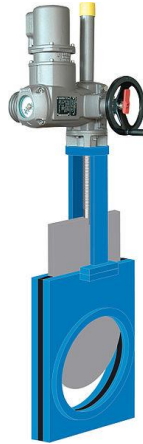

Figure 7.2: A gate valve<sup>58</sup>

- Rotating** – The various types of rotating valves include plug, ball, butterfly, and cone. These types of valves rotate to open and close. Some, for example plug and ball valves are rotary style rotating valves. This means they are quarter or half turn rotary valves. While others like butterfly valves rotate on a shaft to open and close.

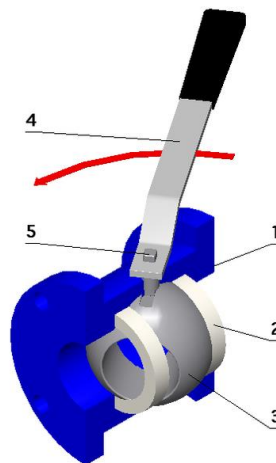

Figure 7.3: 1.) Body 2.) Head 3.) Ball 4.) Lever handle 5.) Stem<sup>59</sup>

In the diagram above, the lever of a ball valve is turned one quarter of the way and the ball that is blocking the flow opens to allow water to flow through. The “ball” that is in the line of flow is solid on each side and is open on the other sides. The rotating cylinder on these valves can also be cone shaped. Smaller plug valves are used on customer service lines. The valve that connects a distribution main to a service lateral is called **corporation stops (corp stop)** and the valve that connects the service lateral to a meter is a **curb stop**. These are also referred to as meter and angle stops. They can be used to throttle flow without being damaged.

<sup>58</sup> [Image](#) by HerbstrittM is licensed under [CC BY-SA 3.0](#)

<sup>59</sup> [Image](#) by Ruben Castelnuovo licensed under [CC BY-SA 3.0](#)



- **Flexing** – The last style of valve based on how it operates is a “flexing” valve. These valves are either diaphragm or pinch style valves. The flow is reduced or stopped by a squeezing or pinching effect to obstruct the flow. The material inside of these valves need to be flexible and are commonly resistant to corrosion.

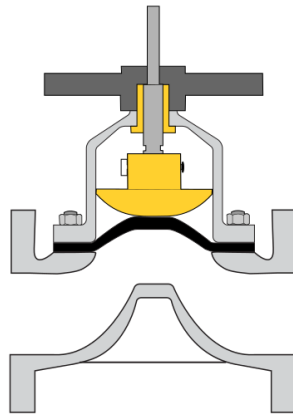

Figure 7.4: A diagram of a rubber lined diaphragm valve<sup>60</sup>

## Gate Valves

Gate valves are one of the most widely used valves in a water distribution system. As previously mentioned their primary function is to start and stop the flow of water. These types of valves should not be used for throttling the flow of water as they can become damaged. The gate (slide) is lowered and raised by a hand wheel in above ground installations and a nut with a key on below ground installations. The face of a gate valve can become worn, especially if they are throttled and objects can become lodged under the gate, which prevents a proper seal.



Figure 7.5: A below-ground gate valve<sup>61</sup>

<sup>60</sup> Image by [Muskid](#) is licensed under [CC BY-SA 3.0](#)

<sup>61</sup> Image by [COC Water Systems Technology Faculty](#) is licensed under [CC BY 4.0](#)



Figure 7.6: An above ground gate valve<sup>62</sup>

The gate picture above (Figure 7.5) is the style used below the ground surface. The nut on top of the valve bonnet is operated with a “T” shaped key with a 2” square case that fits on top of the nut. The other gate valve pictured above (Figure 7.6) is one used in above ground installations and is operated with a hand wheel. There are several different styles of gate valves, and they have various purposes. The list below identifies some of these valves.

- **Non-rising stem (NRS)** – The below ground gate valves are considered non-rising stem. These valves take up less space and have the screw mechanism protected.
- **Rising stem** – A rising stem gate valve is commonly used on fire systems. The reason is because it is easily detected if the valve is open or closed by the position of the stem. These types of valves are also called “outside stem and yoke” or OS&Y valves. The picture depicts this type of valve. When the stem is up, the valve is open.



Figure 7.7: A tee with gate valve<sup>63</sup>

<sup>62</sup> [Image](#) by Heather Smith is licensed under [CC BY 3.0](#)

<sup>63</sup> Image by Mike Alvord is licensed under [CC BY 4.0](#)

- **Horizontal** – In shallow below ground installations, horizontal gate valves are commonly used. They allow for low clearance and they are also easier to operate. Instead of having to lift the gate up when operating, the gate slides to the side. So, in addition to installations when the ground cover is minimum, large valves can also be horizontal gate valves.



Figure 7.8: An example of a gate valve<sup>64</sup>

- **Tapping, Cutting-In, Inserting** – Several styles of gate valves are classified based on the use in construction practices. Tapping, cutting-in, and inserting valves are all used based on adding a valve in an existing distribution system. Tapping valves are used exclusively when a connection needs to be made to a water main. Hence, “tapping” in to the water main. There are two types of taps, wet or hot tap and dry tap. A hot tap is done while the water main is in use and service cannot be disrupted. A dry tap is when the pipeline is shut down and the water is drained from the pipe.



Figure 7.9: Municipal gate valve repair<sup>65</sup>

<sup>64</sup> Image by Mike Alvord is licensed under [CC BY 4.0](https://creativecommons.org/licenses/by/4.0/)

<sup>65</sup> Image by [Rainier5](https://www.rainier5.com/) is licensed under [CC BY-SA 3.0](https://creativecommons.org/licenses/by-sa/3.0/)

The two other methods of adding a valve to an existing water system are cutting-in or inserting. A pipe can be cut and a valve is added or a valve can be inserted into the pipe.

A cutting-in valve was one oversized end connection designed to be used with a cutting-in sleeve. The valve and sleeve are used together to facilitate installation of a new valve in an existing main. Pressure must be shut off for a short time. Inserting valves are installed when water cannot be shut off and the main cannot be depressurized.

- **Resilient seated** – Gate valves are commonly made of various types of metallic materials. However, rubber, urethane rubber, and other synthetic materials are also used to make the closure member. In addition, the seat is made from this same material, providing a tight and complete closing seal.
- **Slide** – Gate valves are sliding (sluice) valves, but a slide gate is a simple gate style valve. They are designed to release large volumes of water at one time and are often found in large agricultural systems. The gate or blade is relatively thin, they do not provide a completely tight shut off, and can be square, oblong, or round in shape.

One of the main advantages of gate valves is the ability to block or let flow happen in both directions. They also offer little to no resistance when fully open and allow a clear waterway for the flow of water. In addition to the various styles of gate valves, they are classified into three (3) main types: double disc, solid wedge, and resilient seated (as previously discussed). A double disc gate valve is made up of two relatively loose fitting discs that, when closed, are pressed against metal seats by a wedging mechanism. Water pushes past the upstream disc and allows the area between the two discs to become pressurized when the discs are in a closed position. The pressure is then released when the valve is opened. Some of these valves are equipped with a bypass to equalize the pressure on both sides to make it easier to open. The main disadvantage is the large frictional on the downstream disc making it difficult to lift off the seat. A solid wedge gate valve involves a closure member that is a single wedge guided into fitted, tapered seats. Although throttling is not recommended with gate valves, the solid wedge is more desirable because of the close guiding between the wedge and the body. Resilient seated gate valves were previously discussed.

## Other Valves

**Plug valves** are a type of rotary valve and can be used to throttle and control flow. Even when open, they cause some flow resistance. There are three basic types of plug valves, lubricated, non-lubricated, and eccentric. With lubricated plug valves, grease is used to lubricate the plug motion and to seal the gap between the plug and the valve body. On a non-lubricated plug valve, the valve is mechanically lifted up from or pushed down to the seat. An eccentric plug valve is a non-lubricated valve that rotates the plug and pulls away from the seat. Another type of rotary valve is a **cone valve**, which are limited in use because of their size and weight, but they are good for controlling flow and provide low flow resistance. **Ball valves** require a 90

degree rotation between the open and closed position, have low flow resistance, and are also suitable for throttling flow.

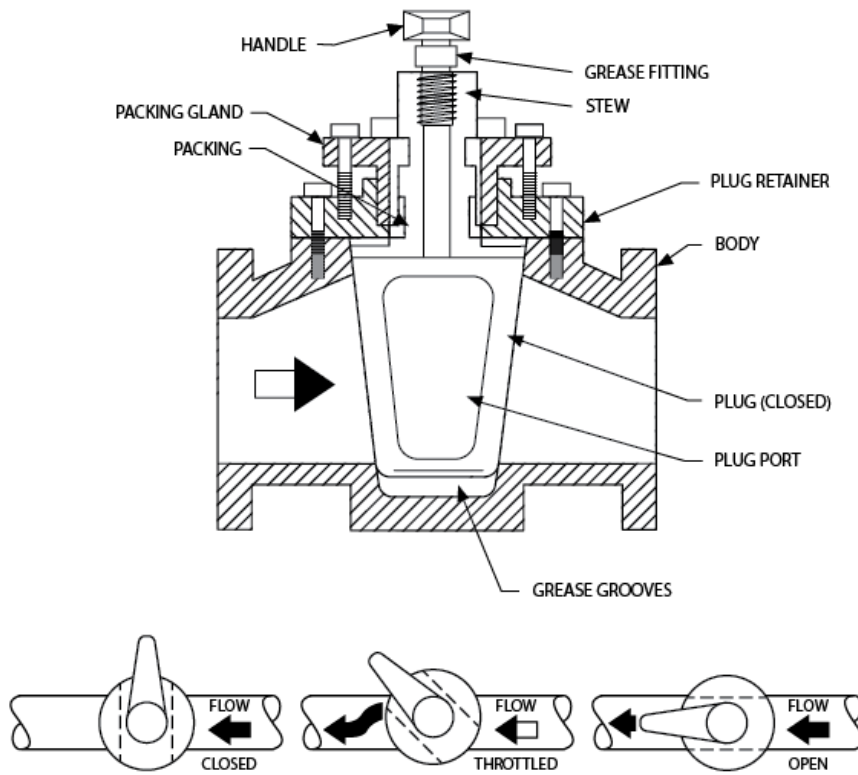

7.10: Plug Valve<sup>66</sup>

<sup>66</sup> [Image](#) by Marilyn Hightower is licensed under CC BY 4.0

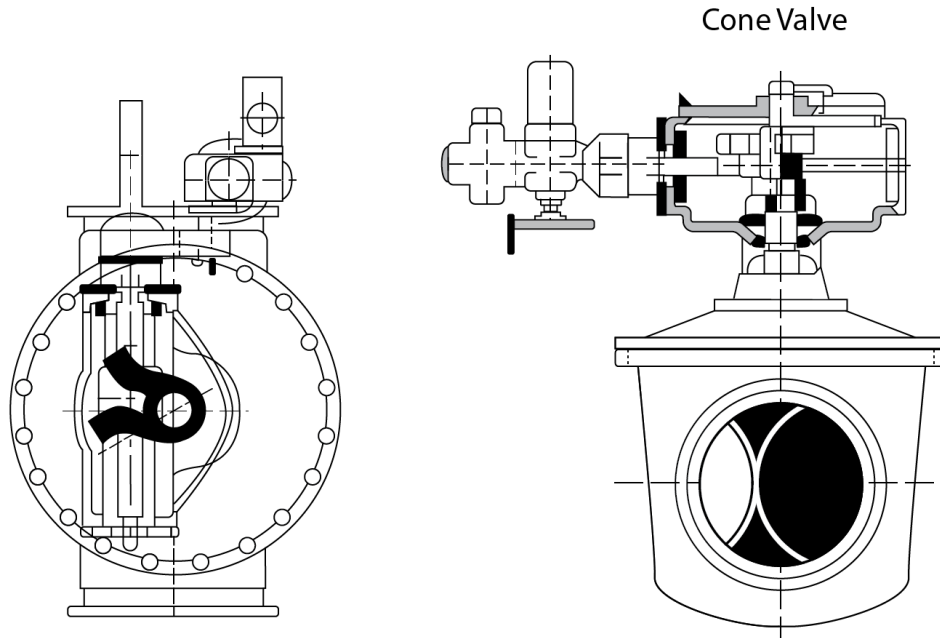

7.11: Cone valve<sup>67</sup>

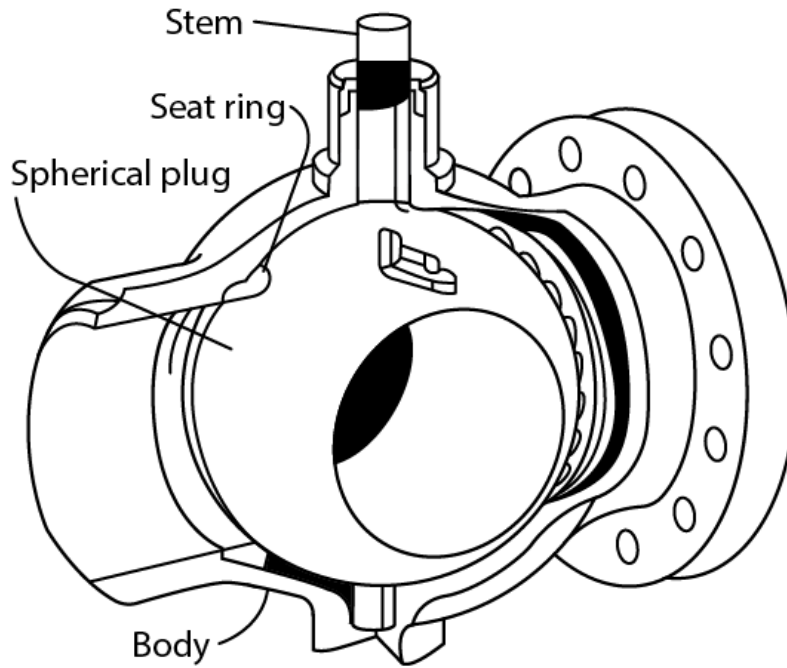

7.12: Ball Valve<sup>68</sup>

Another common valve within the water industry is a butterfly valve. A **butterfly valve** is another valve that rotates. It has a disc similar to a gate valve, but this disc rotates on a shaft to open and close. Butterfly valves are easier to operate than a gate valve because as they open,

<sup>67</sup> [Image](#) by Marilyn Hightower is licensed under CC BY 4.0

<sup>68</sup> [Image](#) by Marilyn Hightower is licensed under CC BY 4.0

the force of the water pushes against the opposite side of the disc helping to open the valve. The main disadvantage to a butterfly valve is that they have a high resistance to flow because the valve, even when fully open, is always in the flow path. The disc can also get damaged from vibration of the flowing water. Since they have a short laying length (distance between each side of the flanges), they are used where space is limited. They are also lighter in weight and less expensive than gate valves.



Figure 7.13: A butterfly valve<sup>69</sup>

A **check valve** allows flow in only one direction and therefore has very specific applications. There are five main types of check valves.

- **Slanting disc** – provide the lowest head loss of any check valve and are commonly used in larger pipelines to save on pumping costs.
- **Cushioned swing** – results in a soft or cushioned closing of the valve when the flow of water stops.
- **Rubber swing** – instead of the valve swinging on a hinge pin, like most other check valves, a rubber swing flexes to open.
- **Double door** – while all check valves are designed to allow flow in only one direction, a double door check valve is designed to have a greater seal when closed. These types of valve are more common in industrial operations.
- **Foot** – these are special types of check valves installed on groundwater wells in order to prevent water from flowing backwards out of a pump and well piping back into the well when the well pump stops operating. They are installed at the bottom of a pump suction line and are used to prime the pump.

<sup>69</sup> [Image](#) by Heather Smith is licensed under [CC BY 3.0](#)

## Relieving and Controlling Pressure

Pressure relief valves are very common in installations where pressures are high or where pressures can spike. These types of valves are used to control the limiting pressure within a system. The pressure is relieved by allowing the water flow to escape through an auxiliary passage out of the system. Preset pressure limits are designed to prevent damage to specific equipment or plumbing systems. Many residential homes and commercial businesses will have pressure relief valves installed if the incoming water pressure from the distribution system is higher than what is acceptable to the building being served. These valves are designed to open when pressures meet these preset values. A spring-activated disk balances the pressures on both sides of the system and opens when the inlet pressure exceeds the set value.

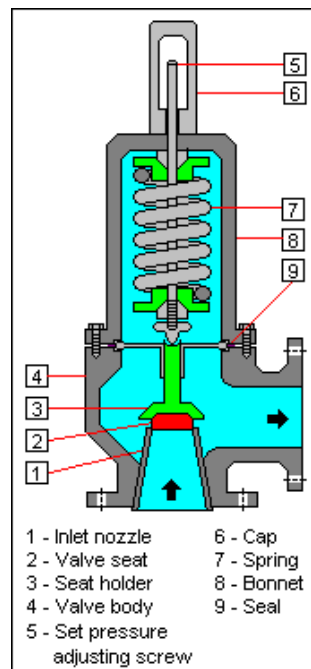

Figure 7.14: The parts of a relief valve<sup>70</sup>

Controlling pressure is another function of water system valves. If pressures are too low a water system is sometimes incapable of supplying the needs of customers. More importantly, if pressures are very low, the water system might be unable to provide adequate flows for fighting fires. If pressures are too high and relieving the pressure outside of the system is not possible, controlling valves can also be used. In some systems, both relief and controlling valves can be used. For example, the pressures within a system may fluctuate higher and lower beyond what are considered adequate pressures and a control valve would be installed. However, if the chance of extremely high pressures exists, then a relief valve would also be installed. Pressure control valves use hydraulic pilot systems which allow for a high pressure set point for high flow demands and a low pressure set point for low demands.

<sup>70</sup> Image by Mbeychok is licensed under [CC BY-SA 3.0](https://creativecommons.org/licenses/by-sa/3.0/)



The valve then automatically adjusts the pressure across the valve to accommodate these pressure ranges. This prevents the system from having too high or too low pressures.



Figure 7.15: A relief valve<sup>71</sup>

## Backflow Prevention

Preventing the contamination of a drinking water is an important aspect of a water distribution system. When a non-potable water supply is connected to a potable water supply the possibility of a cross connection between these two sources exists. Therefore, every water utility needs to have a cross connection control program. Cross connection control and backflow prevention is discussed in another section of this text. In this section, we will look at the actual methods and devices used to prevent the flow of non-potable water back into a potable water supply system.

The safest way to prevent a cross connection is by not connecting non-potable supplies with potable supplies. When complete isolation of two supplies is not possible, a backflow method can be accomplished with an air gap. A proper air gap has the source supply discharging water into a receiving supply. This air gap distance between the source supply and the receiving supply must be two times the diameter of the supply pipe or one inch, whichever is greater.

---

<sup>71</sup> [Image](#) by Markus Schweiss is licensed under [CC BY-SA 3.0](#)

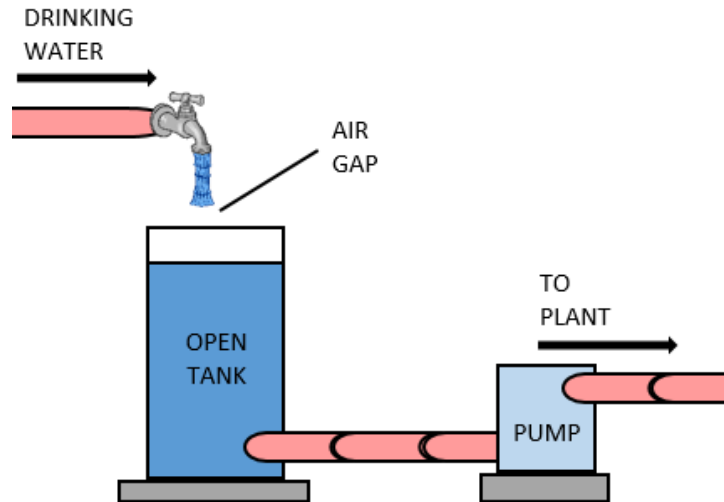

Figure 7.16: A backflow prevention diagram<sup>72</sup>



Figure 7.17: An air gap<sup>73</sup>

When complete separation is not possible, a backflow prevention device can be used. These types of valves are reduced pressure principal, double check, or vacuum breakers.

A **reduced pressure principal (RP) backflow device** consists of two spring-loaded check valves with a pressure-regulated relief valve between the two. Under backsiphonage conditions, both

<sup>72</sup> Image by [frankes](#) is licensed under [CC0 1.0](#) (modified by [COC OER](#))

<sup>73</sup> Images by the [Ohio EPA](#)

checks will close and the relief valve will open. If there is backpressure in excess of the water main, both check valves will also close. If leakage occurs in the second valve, it will be allowed to escape through the center relief valve. It is important to install these devices high enough where the relief valve cannot be submerged in water. RP devices are used in commercial, industrial, and irrigation installations.

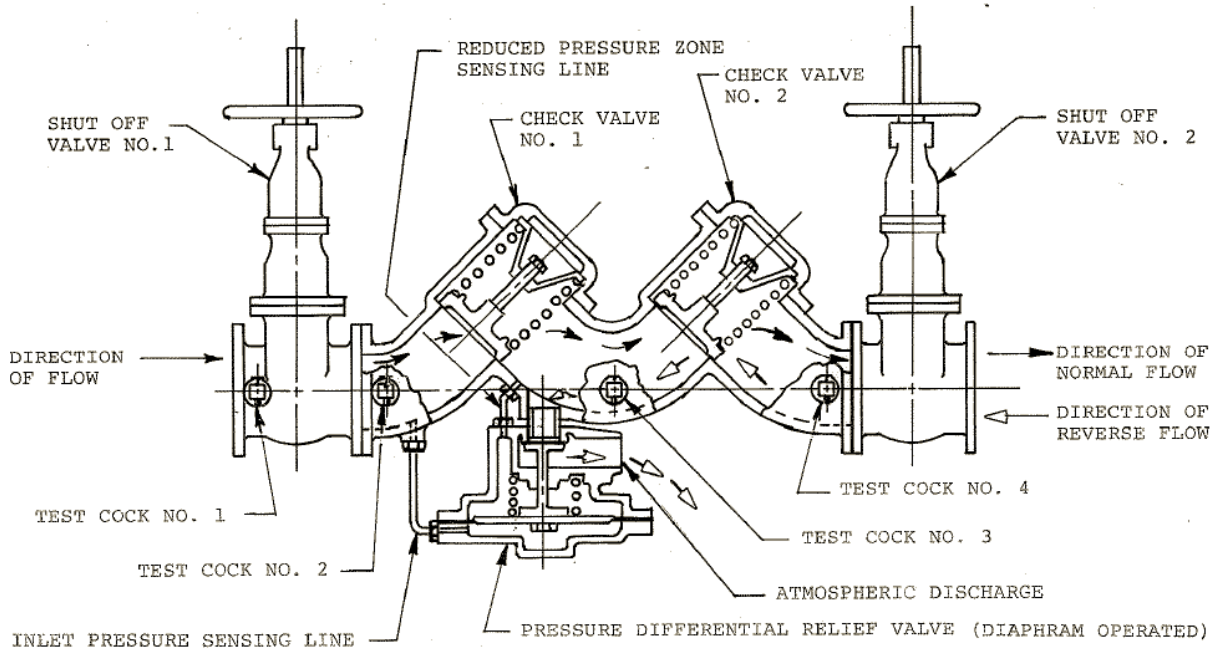

Figure 7.18: A double check valve diagram<sup>74</sup>

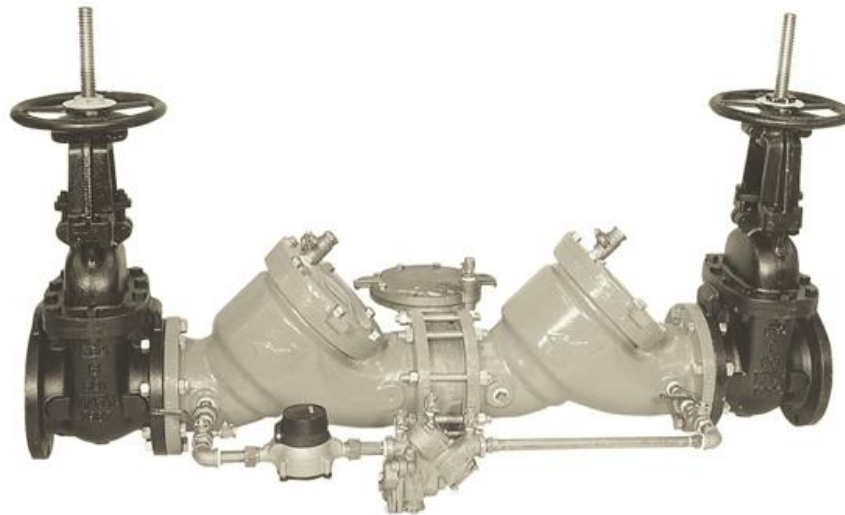

Figure 7.19: A double check valve<sup>75</sup>

<sup>74</sup> Image by the [Ohio EPA](#)

<sup>75</sup> Image by the [Ohio EPA](#)

**Double check (DC) valve devices** are similar to RP devices, except they do not have a relief valve in the center. Therefore, the protection is not as positive and should not be used where a health hazard may result. DC valves are commonly used in fire sprinkler installations.

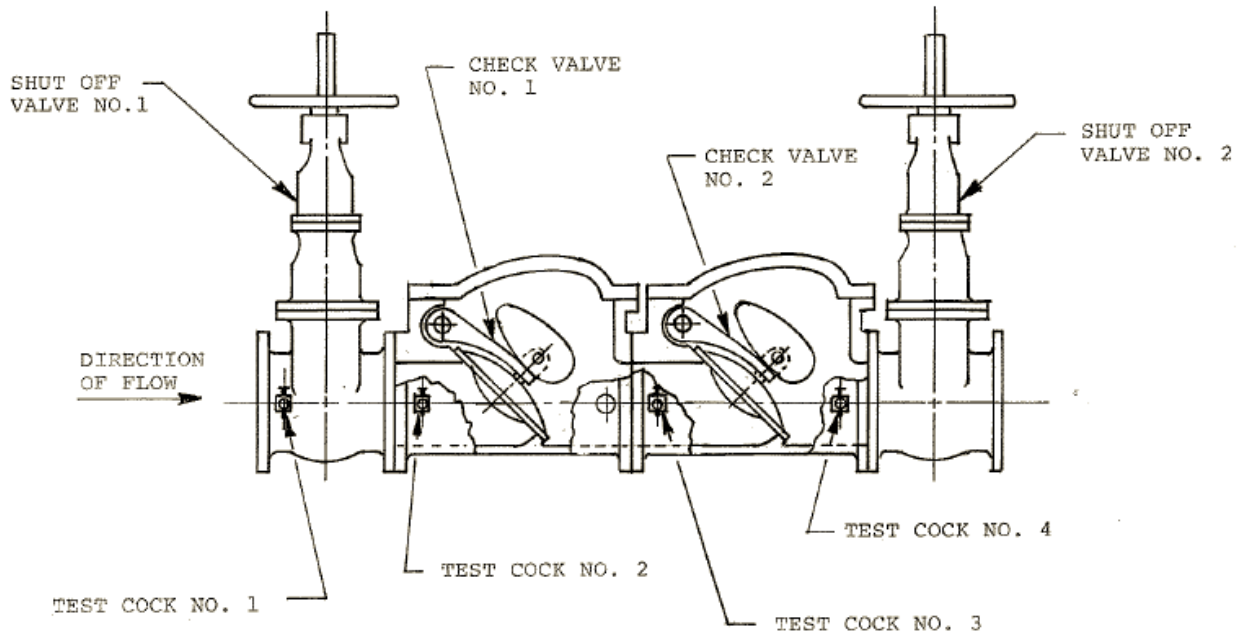

Figure 7.20: A backflow prevention device diagram<sup>76</sup>

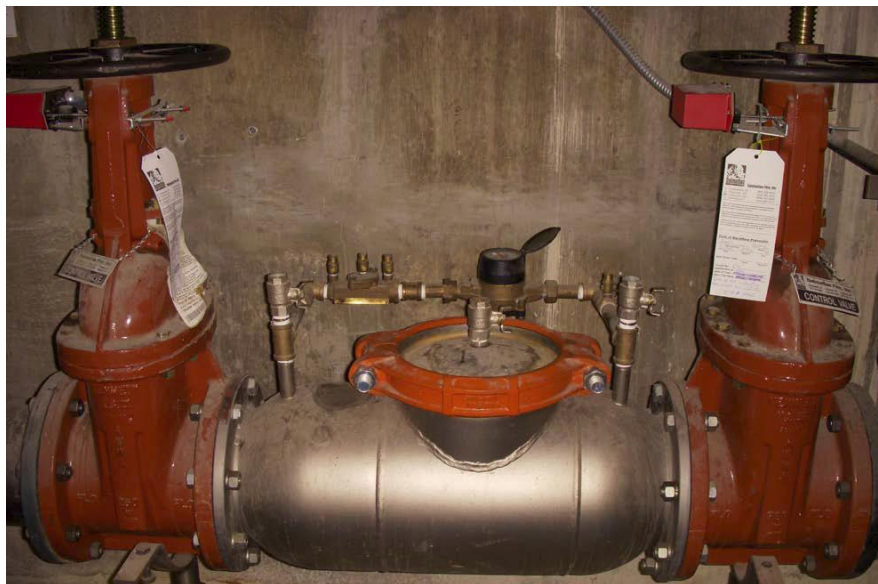

Figure 7.21: A backflow prevention device<sup>77</sup>

<sup>76</sup> Image by the [Ohio EPA](#)

<sup>77</sup> Image by the [Ohio EPA](#)

Installations where water use is only needed during an emergency, as with a fire sprinkler system, an RP or DC device can be installed with a meter attached. This meter will detect any flow of water through the device and allow the utility to bill the customer for this usage. These meters are referred to as detector assemblies. Therefore, an RPDA would be a reduced pressure principal detector assembly and a DCDA a double check detector assembly. Backflow prevention devices are required to be monitored and maintained. Most cross connection control programs require annual testing.

There are other types of devices used where health hazards do not exist and are designed for intermittent use. These devices are called vacuum breakers. There are two main types of vacuum breakers, atmospheric and pressure. Common installations include lawn sprinkler systems, janitor sink faucets, and toilet flush valves. Atmospheric vacuum breakers must be installed beyond the last valve in the piping system. When the supply pipe is under pressure, the check valve closes against an upper seat to prevent leakage. When there is no pressure, the valve drops and allows air to enter the discharge pipe preventing backsiphonage. If there is continuous pressure the valve may malfunction. Pressure vacuum breakers are designed for use under pressure for long periods of time. They should not be used where backpressure is possible on the discharge side and they must be installed above the highest fixture in the system.

## Valve Maintenance

Since valves are mechanical devices, they need to be properly maintained. There is a wide variety of different types and uses of valves throughout the water industry and each type has their own maintenance requirements. As previously mentioned, backflow prevention devices require frequent testing and proper maintenance. The seats of a valve can become worn and damaged and need to be replaced periodically. The springs, which operate the valves and allow them to open and close, need to be replaced from time to time. This sort of maintenance is not only required with backflow devices, all valves need to be monitored and maintained.

Distribution system valves are usually left in the open position to allow water to flow throughout the system. However, in the event of a leak or some other emergency, where the flow of water needs to be stopped, a valve needs to be closed. If a valve is left in the open position for years, closing it may prove to be difficult. Why? Because any mechanical device which has not been operated over a long period of time can become stuck or frozen. Therefore, it is important to operate valves on a routine basis. This routine maintenance operation of distribution system valves is referred to as valve exercising. Exercising a valve is nothing more than operating the valve from its current condition (open or closed) to the other position. Each valve type and valve size has a known amount of turns required to open and close it and the operator should be mindful of the number of turns in order to determine if the valve is in good working condition. If the valve cannot be operated to the required number of turns, it could be damaged or broken and might need to be replaced. A good valve exercise program should include all the information about the valve so the operator can make an assessment as to whether or not the valve is in good working condition. If not, then the valve should be put on a replacement schedule.

Valves are an important part of any water utility system and provide a variety of uses, from stopping and starting flows, allowing flows in only one direction, reducing pressure, relieving pressure, and controlling pressure. These are some of the more critical uses of water system valves.

#### Key Terms

- **ball valve** – a type of valve with a 90 degree rotation between open and closed position, low flow resistance and suitable for throttling flow
- **butterfly valve** – a valve that rotates with a disc similar to a gate valve, but this disc rotates on a shaft to open and close; easier to operate than a gate valve because as they open, the force of the water pushes against the opposite side of the disc helping to open the valve
- **check valve** – a valve that allows flows in only one direction and therefore has very specific applications
- **cone valve** – a type of rotary valve that is good for controlling flow and providing low flow resistance
- **corporation (corp) stop** – the valve that connects a distribution main to a service lateral
- **curb stop** – the valve that connects the service lateral to a meter
- **double check (DC) valve devices** – similar to RP devices, except they do not have a relief valve in the center
- **pigging** – the process to clean the inside of a water main
- **plug valves** – a type of rotary valve that can be used to throttle and control flow
- **reduced pressure principal (RP) backflow device** – consists of two spring-loaded check valves with a pressure-regulated relief valve between the two valves

## Review Questions

1. What are the four principle uses of valves in a distribution system?
2. What is the one of the most widely used valve in water distribution? Describe the different ways it can be operated (on and off).
3. What offers the greatest protection to backflow prevention? Why is backflow prevention important?

## Sample Questions

1. Which of the following valves is not compatible with a process known as “pigging”?
  - a. butterfly
  - b. gate
  - c. ball
  - d. all are compatible
2. Which of the following valve should not be used for throttling?
  - a. butterfly
  - b. gate
  - c. ball
  - d. plug
3. Which backflow device provides the most protection?
  - a. double check
  - b. reduced pressure
  - c. vacuum breaker
  - d. all are equal
4. Which valve is used to prime a groundwater well pump?
  - a. butterfly
  - b. gate
  - c. ball
  - d. foot
5. Which of the following valves would be considered a “closing down” type?
  - a. gate
  - b. globe
  - c. butterfly
  - d. both a and b



## CHAPTER 8 – HYDRANTS

This chapter we will examine water distribution fire hydrants and their uses. After reading this chapter, you should be able to:

### OBJECTIVES

After reading this chapter, you should be able to:

- describe the different types of fire hydrants;
- explain the different uses of fire hydrants; and
- identify the operational and maintenance criteria for fire hydrants.

From a very early age, we are exposed to fire hydrants. Many kids story books have pictures of red fire hydrants and Dalmatian dogs.



*Figure 8.1: A fire hydrant<sup>78</sup>*



*Figure 8.2: A dalmatian<sup>79</sup>*

---

<sup>78</sup> Photo by [Ashim D'Silva](#) on [Unsplash](#)

<sup>79</sup> Photo by [Tim Zänkert](#) on [Unsplash](#)

We start recognizing the red fire plug and associate it with firefighting. However, most fire hydrants we see every day are not red. They are yellow. The use of fire plugs or fire hydrants as we know them today dates back to the 1600s. After a devastating fire destroyed a large portion of London, predrilled holes were added to new water mains and plugs were installed above ground for access. Since early water mains were made out of wood, the early hydrants were holes that had above ground plugs, hence the term “fire plug”. By the 1800s, cast iron hydrants replaced the traditional fire plugs.



Figure 8.3: A yellow fire hydrant<sup>80</sup>

## Fire Hydrant Uses

The most common and understood use of a fire hydrant is fighting fires. Public fire protection is important for any community and it is the responsibility of water utilities to provide fire hydrants in required locations and the water required for fighting fires. There are other uses of fire hydrants. Some of these uses include flushing water pipelines, storm drains, and sewers, street washing, public landscape watering, and construction. Let’s take a look at some of these less obvious uses.

## Flushing Water Pipelines, Storm Drains, and Sewers

When a new water pipeline is installed there are various things that need to be done before the pipeline can be connected to the distribution system and used for public water supply. New pipelines need to be disinfected and sampled to make sure the water in the pipe is safe for human consumption. After this disinfection and sampling process, the water needs to be flushed out and replaced with fresh water. This flushing process is commonly performed by the use of fire hydrants. Water in pipelines can also become stagnant if there is little or no use. An example of this would be a cul-de-sac where there is little to no use. Perhaps it is a long cul-de-sac with only one home and the homeowners are out of town for an extended period of time. The water in the pipeline could become stagnant and when the homeowners return may notice

---

<sup>80</sup> Image by [Matt Gregory](#) is licensed under [CC BY-ND 2.0](#)

some taste and odor problems with the water. If the water utility is notified of these types of issues they would often times flush the water out of the pipeline to replace it with fresh water. Storm drains and sewers also need to be cleaned from time to time. If debris blocks the flow in these systems, hoses are often connected to fire hydrants in order to push the debris and flush these piping systems. It is important to make sure the potable drinking water distribution does not become contaminated from storm drains and sewers. Often times certain valves known as back flow devices are used or water trucks are filled through fire hydrants and then these piping systems are flushed.

### Street Sweeping and Landscape Watering

In order for city streets to stay clean, vehicles such as street sweepers are commonly used. A street sweeper will connect to a fire hydrant in order to fill up a tank and then the water is discharged to clean the street. A lot of streets have center medians with landscaping which include trees and other plant material. If these medians are not equipped with irrigation systems, water trucks are often used to water these plants. The water to fill these trucks comes from fire hydrants.



Figure 8.4: A water truck<sup>81</sup>

### Construction

Construction needs water for various purposes. One of the most common uses of water (supplied through fire hydrants) is for dust control. During grading operations heavy equipment moves and removes dirt, sometimes over large areas. This process of dirt moving creates dust. In order to control the dust, water trucks collect water from fire hydrants and spray it over the entire area to wet the dirt controlling the dust.

---

<sup>81</sup> [Image](#) by Ildar Sagdejev is licensed under [CC BY-SA 4.0](#)

## Is water from fire hydrants free?

Unlike water served to customers such as home or business owners, water coming from a fire hydrant is not metered. When a fire truck pulls up to a fire hydrant, connects a hose to the hydrant, and starts to fight a fire, the water used is not metered. In other words, there is nothing to track the amount of water used and there is no one paying for the water being used. Since fighting fires is a public service, it actually makes sense that the water used is not metered and sometimes emergencies occur when a connection needs to be made quickly. There are some uses from fire hydrants, which should be metered, and the water paid for by the user. Most other uses of water from fire hydrants besides fighting fires is metered for use. Portable hydrant meters are used to keep track of the water used. These meters, often referred to as construction or hydrant meters, are temporary meters rented to the user. Since these meters are temporary in nature and can be used in multiple locations the user is sometimes asked to provide the meter reads.



*Figure 8.5: Pumping water out from a fire hydrant<sup>82</sup>*

By charging for water used from fire hydrants there is accountability of the water and it also discourages the wasting of water. It is important for water utilities to account for all the water within a water distribution system. It costs the utility to pump the water throughout the distribution system, so when water leaves the system unaccounted for, there is lost revenue. This lost water is measured by utilities and is referred to as water loss.

There are several ways water utilities monitor and control the use of water from fire hydrants. Specific meters are assigned and used only for connecting to fire hydrants. These meters are commonly referred to as construction or hydrant meters. Often times, deposit fees are charged to “rent” these meters. Deposits are designed to cover cost of the meter in case they are lost or damaged. These fees can also be used to maintain and service these meters to make sure they work and measure flow accurately. Some utilities use a permitting process to issue these meters. This process is designed to help track the meters being issued and often includes a fee, which provides the same coverage for maintenance and replacement costs.

---

<sup>82</sup> [Image](#) by the [U.S. Air Force](#) is in the public domain

## Parts of a Fire Hydrant

There are several parts of a hydrant and can be broken into the upper and lower section. The upper section consists of the nozzle and head. The nozzles are the areas where hoses or meters can be connected and where the water flows from the hydrant. These connections are commonly 2 ½” and 4” in diameter, threaded, and caps are usually provided to cover and protect the threads.



Figure 8.6: The caps and nozzles of a fire hydrant<sup>83</sup>



Figure 8.7: Closing a fire hydrant bonnet<sup>84</sup>

The top section of a hydrant can also be referred to as the **bonnet**. The bonnet is the top cover or enclosure. There is an upper barrel portion that sits above the ground and a lower buried portion, often times referred to as the “bury-el”. This buried elbow portion is shown below.

<sup>83</sup> [Image](#) by [Ben Schumin](#) is licensed under [CC BY-SA 2.5](#) (modified by [COC OER](#))

<sup>84</sup> [Image](#) by the [U.S. Air Force](#) is in the public domain



Figure 8.8: A workman installs a new fire hydrant<sup>85</sup>

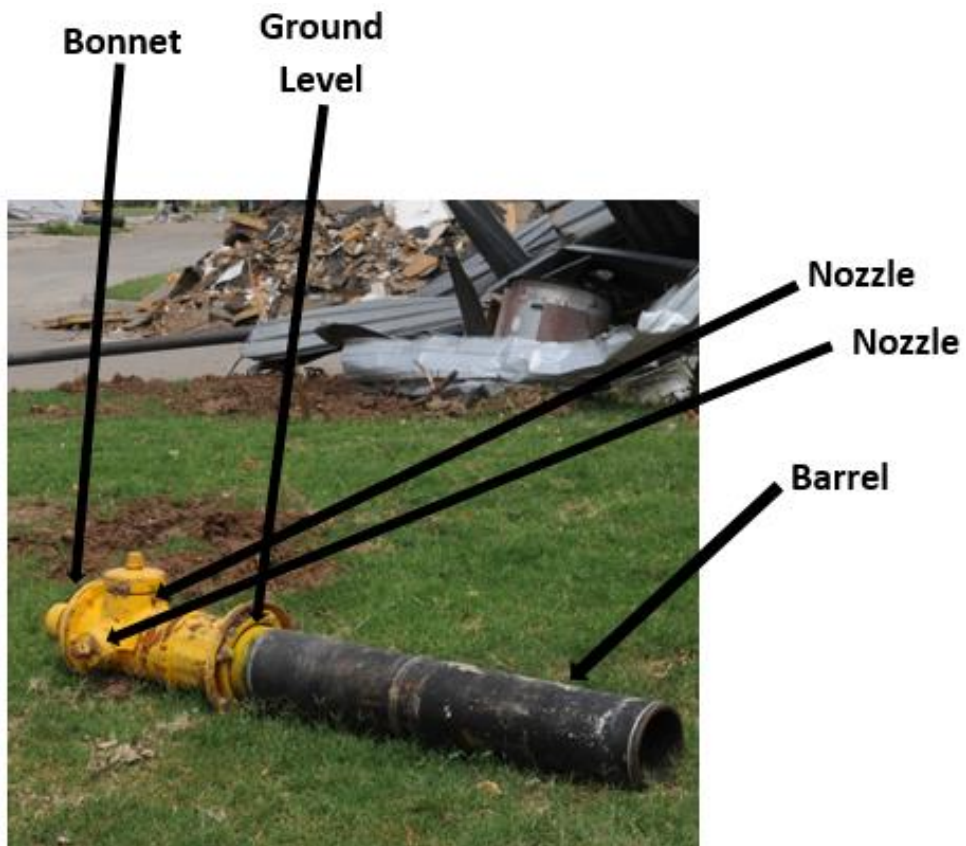

Figure 8.9: The different parts of a fire hydrant<sup>86</sup>

<sup>85</sup> Image by FEMA is in the public domain

<sup>86</sup> Image by FEMA is in the public domain

## Types of Fire Hydrants

On the surface, most fire hydrants look similar. They are usually molded in cast or ductile iron, bronze, and sometimes steel. They are typically constructed above ground with threaded openings for the attachment of hoses. However, there are a few different types of fire hydrants. The first two we will look at are the dry barrel and wet barrel hydrants.

### Dry Barrel Hydrants

A dry barrel hydrant is exactly that: a hydrant with the barrel dry. The barrel of a hydrant is the body above ground and a section below ground. The picture below depicts the barrel. This type of fire hydrant is very common in areas where the weather drops below freezing. In these areas, the barrel of a hydrant needs to be dry in order to prevent the water in the barrel from freezing. If the water in a barrel of a fire hydrant freezes, then the ability of the fire department to access water in order to fight fires is impeded.

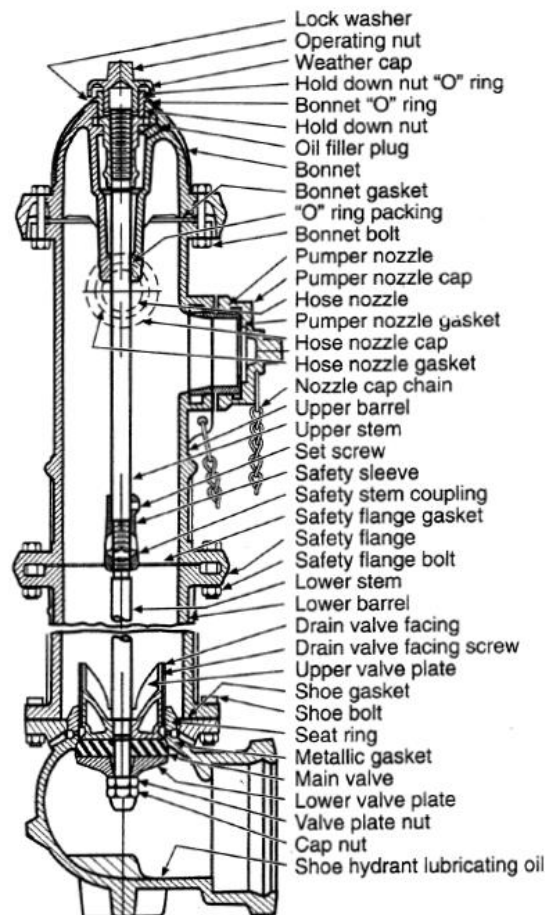

Figure 8.10: A dry barrel fire hydrant diagram<sup>87</sup>

There is a nut at the top of a dry barrel fire hydrant, which is connected to a stem. This stem connects to and operates a valve, which allows water to enter the hydrant barrel, and water

<sup>87</sup> Image by the [U.S. Fire Administration](#) is in the public domain

can flow. There are two types of dry barrel fire hydrants: wet-top and dry-top. A **wet-top dry barrel hydrant** is constructed such that the threaded end of the stem and the operating nut are sealed from water when the valve is open. A **dry-top dry barrel hydrant** has the threaded end of the stem sealed off from water in the barrel when the hydrant is filled with water and in use. This design reduces the possibility of the threads becoming fouled by sediment or corrosion. The type of operating valve can further classify a dry barrel hydrant. These types of valves include: standard compression, slide gate, and toggle.

- **Standard compression** – This type of hydrant valve closes the water against the seat of the valve to aid in providing a good seal.
- **Slide gate** – A slide gate is a gate valve similar to a distribution system gate valve.
- **Toggle** – This type of valve closes horizontally and the hydrant barrel extends well below the branch line. This type of valve is also called a “Corey” valve.

### Wet Barrel Hydrants

Wet barrel hydrants are used in warm climates where the risk of freezing is minimal. Since most fire hydrants are above ground and exposed to the elements, it is important that the water inside the hydrant doesn’t freeze when the temperatures dip below freezing temperatures. However, it is also important that a fire hydrant flows water when it is opened. This is the design of a wet barrel hydrant. When the valve stem adjacent to a threaded opening is twisted open, water flows directly out of the hydrant.

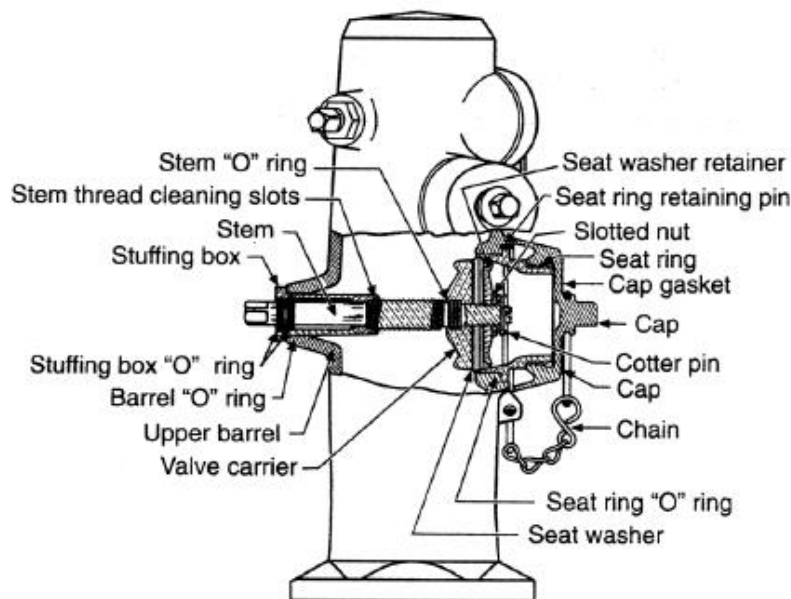

Figure 8.11: A wet barrel fire hydrant diagram<sup>88</sup>

### Locating Fire Hydrants

Fire hydrants need to be properly located in order for ease of access and properly spaced in order to give proper coverage for fire fighters. Hydrants are typically located at street

<sup>88</sup> [Image](#) by the [U.S. Fire Administration](#) is in the public domain



intersections and spaced between 350 and 600 feet apart. The spacing is dependent on the type of structures in the area (residential, commercial, etc.) and the density of the buildings. Commonly they are placed about two (2) feet from the back of curb face and located far enough away from buildings to allow the fire department to gain access without being too close to fire. When installed along public roadways on sidewalks, care must also be taken to install them so they do not impede foot traffic or wheelchairs.

Since fire hydrants are commonly installed where there is vehicular traffic, the potential for one to get hit by a vehicle is likely. Therefore, proper installation must be considered in order to provide the least amount of damage. Several methods are commonly used. One method is to use hollow bolts, which connect the flange above ground to the flange below ground. Another method employs the use of a “break away” flange. This type of flange is manufactured to split in the center. Both of these methods allow for the hydrant to break away from the below ground barrel. This prevents the buried components from being damaged and allows for the hydrant to be reinstalled relatively easy without any excavation.

### Potential Problems

As discussed above, hydrants are not just operated by water utility operators. Fire departments, City workers, construction workers, and others can and often do operate a fire hydrant for various reasons and uses. This presents a potential problem. Older hydrants may not seat (close) properly and leak after it is closed. Opening a hydrant at the end of a cul-de-sac may stir up sediment in a pipe causing water quality issues and concerns. Proper traffic control must be taken when a hydrant is open on public streets with traffic. When a hydrant is open, it can disrupt the flow of traffic by spraying water across lanes. Whenever a hydrant is open to flow onto the ground, proper drainage needs to be available. If storm drains and gutters are filled with debris, water may not be able to drain properly and some of this debris can be flushed into storm drains ending up in local waterways. Another problem that can occur when a hydrant is improperly opened and closed is something called “water hammer”. Opening or closing a hydrant too fast can cause the flow of water to move or stop too rapidly causing damage to pipes and other appurtenances.

It is important to understand the need and various uses of fire hydrants. They play an important role to the surrounding community, public safety, safety to property, and a variety of other uses.

### Key Terms

- **bonnet** – the top section of a hydrant
- **dry-top dry barrel hydrant** – a hydrant that has the threaded end of the stem sealed off from water in the barrel when the hydrant is filled with water and in use
- **wet-top dry barrel hydrant** – a hydrant that is constructed such that the threaded end of the stem and the operating nut are sealed from water when the valve is open

## Review Questions

1. What is the primary use for fire hydrants? What are some other uses of fire hydrants?
2. Describe how climate can dictate the type of hydrant that a water agency would choose.
3. What is the role a water agency plays in public safety? How is this carried out concerning fire hydrants?

## Sample Questions

1. A fire hydrant referred to as a “Corey” style would be what type?
  - a. flushing
  - b. wet barrel
  - c. dry barrel
  - d. none of the above
  
2. What is a name for the base or buried portion of a hydrant?
  - a. bonnet
  - b. cap
  - c. nozzle
  - d. bury-El
  
3. Which is not an approved use of a fire hydrant?
  - a. dust control
  - b. fighting fires
  - c. cooling the public during heat waves
  - d. flushing sewers
  
4. Which of the following is an advantage of a dry-barrel hydrant?
  - a. water is easily withdrawn by opening an operating nut
  - b. water will not flow if the hydrant gets hit and knocked off its base
  - c. water will not freeze in the hydrant body
  - d. both b and c
  
5. What is a wet-top fire hydrant?
  - a. wet barrel hydrant
  - b. flushing hydrant
  - c. dry barrel hydrant
  - d. all of the above

# CHAPTER 9 – METER SERVICES

This chapter we will examine water distribution meters and services.

## OBJECTIVES

After reading this chapter, you should be able to:

- describe the different types of water meters and services;
- explain the different uses of water meters; and
- identify the operational and maintenance criteria for water meters.

## Why Water Meters?

What is the purpose and need for a water meter? Are water meters always used by water utilities? What does a water meter do and where are they used? What is a water meter? These and other questions will be answered in this text.

## Purpose of a Water Meter

The primary purpose of a water meter is to monitor and record the amount of water being used by a customer. These customers can be homeowners, commercial buildings, industrial customers, other water utilities, and various other customers. The idea of “metering” water usage can be traced back to the early sixteenth century. However, if it rained enough to water crops and landscaping, if water was readily available equally for everyone, there might not be a need for water meters. However, it wasn’t until the early nineteenth century when water meters began to be more widely used. The increase in use coincided with the growth of urbanization and industrialization.

While metering the flow of water is very common among residential and commercial drinking water supply customers throughout much of the world, it is less common with irrigated agriculture customers. Metering is also less common in rural areas and in areas where water is in abundance.

In many parts of the world, water is not always easily accessible and in order for the “people” delivering the water to communities to recover all the costs associated with delivering this coveted resource, meters are used. One of the main uses of a water meter is to measure the amount of water delivered to customers. However, meters are used to measure other volumes of water in addition to what is delivered to a customer.

## Types of Water Meters

While there are many different styles of water meters, they are all based on two main methods for measuring flow: displacement and velocity. Displacement meters physically move (or displace) a given amount of water passing through the meter. Velocity meters measure the speed at which the flow of water is passing through the meter. There are a number of different water uses and meters are commonly selected based on size and need. For example, you

wouldn't want to select a small meter if very high volumes and flows are needed. Likewise you wouldn't want a large meter for a single-family home. Displacement meters are commonly used in small to medium flow installations and velocity meters in areas where large flows are required.

## Positive Displacement Meters

**Positive displacement (PD) meters** are commonly used for single-family residential water uses. They are very accurate in measuring low intermittent flows. They work by means of a nutating disk or rotating piston, which creates a rotary motion transmitting to gears and then to the register. PD meters are not designed to operate at full flow for extended periods of time. Normal flows for a PD meter should not be more than approximately one half of the maximum capacity in order to extend the life of these types of meters. Common sizes range in diameters from 5/8" to 2". If PD meters are too large for the required use, lower flows will not be properly registered. For example, if a 2" PD meter is used for a one bedroom apartment where only indoor water use occurs, lower flows such as when someone is brushing their teeth or filling a glass of water may not be accurately measured. PD meters almost never over register and continuous operation at the maximum flow rates will quickly destroy the meter. They are designed with threaded ends and are not tapered. Therefore, a coupling with a gasket is needed for installations. This type of design allows for quick and easy installation and removal. **Piston PD meters** operate by the means of a piston, which moves back and forth as the water flows through. A specific quantified volume is measured for each piston rotation. This rotating motion is transmitted to a register through a magnetic drive connection and series of gears. **Nutating-disk PD meters** use a measuring chamber containing a flat disk. As water flows through, the disk wobbles and rotates (nutates) sweeping out a specific volume of water on each cycle. The rotary motion is transmitted to a register.

## Velocity Meters

**Velocity meters** measure the flow through a chamber of specific size and known capacity. The speed of the flow is converted into volumes correlating to water usage. There are several types of velocity meters, which include, single-jet, multi-jet, turbine, and propeller meters. Electromagnetic and ultrasonic meters are also technically velocity type meters, but will be discussed later in a separate section.

**Multi-jet meters** use a multiblade, multiport rotor mounted on a vertical spindle within a measuring chamber. Water enters this chamber through several tangential orifices around the circumference and leaves through another set of orifices set at a different level. The "jets" of water rotate an impeller where the rotation transmits to a register. Installations requiring low flows, multi-jet meters range in sizes from 5/8" to 2". Internal strainers are often used in order to protect the jet ports from getting clogged. Unlike PD meters, multi-jet meters can overregister. Multi-jet meters have two basic designs. One design is referred to as a "wet" register design and the other a "dry" register. In a dry register design, the register, which sits at the top of a meter, can be removed without shutting the water supply off. This is a desirable

design when a register stops working or becomes damaged and can be replaced easily without disrupting usage.

**Turbine and propeller meters** measure the flow of water by means of a rotor. Each revolution of the rotor is proportional to the volume of water. The rotor has blades, which are angled to transform energy from the flow stream into rotational energy. The rotor shaft spins on bearings and as the water propels through the meter faster, the rotor spins proportionally faster. The accuracy is not good at low flow rates because there is some drag between the rotor and the bearing, which slows the rotation of the rotor. Propeller meters are similar to turbine meters. The main difference is with the rotating element. A propeller is made of thick molded plastic and faces directly into the flow and is suspended by a single bearing assembly. In contrast, the thinner rotor in a turbine meter is supported on both sides by two lighter weight-bearing assemblies. Common installations of turbine meters are uses where the flow is high and the variance in the flow is minimal. For example, irrigation system flows are commonly measured using a turbine meter (below right). In these installations, the flow is constant and steady. Propeller meters (below left) have similar uses, but are more commonly found on source supply installations, for example on a groundwater well. These installations also have a constant steady stream of high flows.

### Venturi and Orifice Meters

A **venturi meter** consists of an upstream reducer, a short throat piece, and a downstream expansion section. An increase in the flow velocity results in a corresponding pressure drop and the flow rate can be deduced. As the flow of water moves through the contraction in the pipe, it speeds up and so, the pressure drops. By measuring the upstream and downstream pressures, the fluid velocity and flow rate can be calculated.

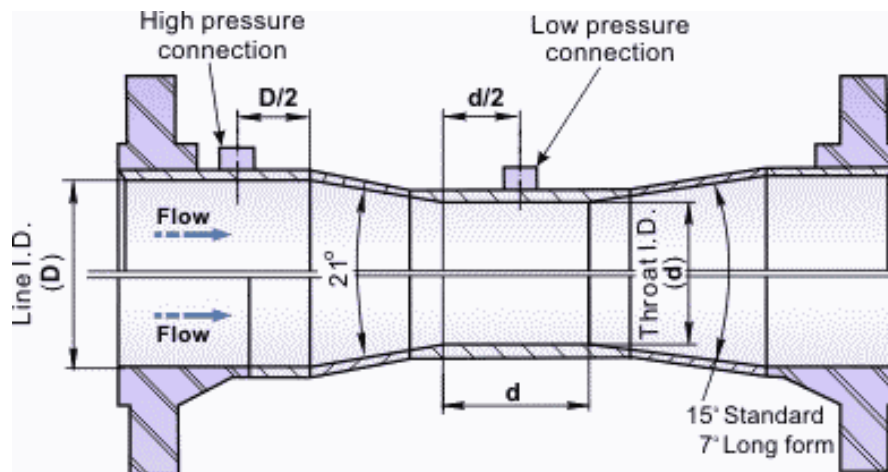

Figure 9.1: A Schematic diagram of venturi meter<sup>89</sup>

An orifice meters operates in much the same way as a venturi meter. A thin plate with a hole in the center of it is installed between two flanges. The flow rate is then calculated by measuring

<sup>89</sup> [Image](#) by Aadilnashit is licensed under [CC BY-SA 4.0](#)

the pressures on both sides of the plate. These types of meters are considered differential pressure meters.

### Magnetic and Ultrasonic Meters

Ultrasonic and **magnetic meters** operate in a similar fashion. They measure the rate of flow without any moving parts to disrupt the path of the flow. Magnetic (or Mag) meters measure the flow of water using an electromagnetic field resulting in a potential difference proportional to the flow velocity perpendicular to the electrical sensors. The pipe must be properly insulated in order to prevent corrosion from the electrical current. Ultrasonic flow meters use ultrasound frequencies to calculate a volume of flow. Transducers are used to emit a beam of ultrasound against the direction of flow. The pulses are sent in opposite diagonal directions and the sound changes with the velocity of the flow. These types of meters tend to have higher initial costs, but the ongoing maintenance costs are minimal because there are no moving parts to maintain or replace.



Figure 9.2: An ultrasonic meter<sup>90</sup>

### Weirs and Flumes

Some water systems such as when an open channel is providing a water supply to a community, a different structure is needed to measure the flow. In this particular system a traditional style meter is not appropriate. An obstruction referred to as a weir is placed across the flow path to measure watersheds, creeks, and stream flows. The depth to which the water rises above the bottom of the weir is directly proportional to the flow. There are two main types of weirs, rectangular and V-notch. Rectangular weirs are constructed in a variety of different configurations including contracted, suppressed, broad crested, and sharp crested.

---

<sup>90</sup> Image by Mike Alvord is licensed under [CC BY 4.0](https://creativecommons.org/licenses/by/4.0/)

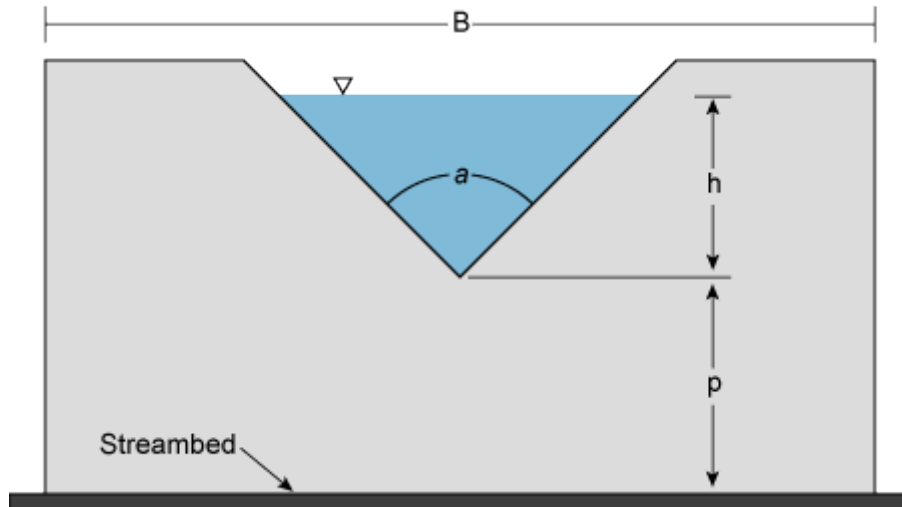

Figure 9.3: A triangular or V notch weir diagram<sup>91</sup>

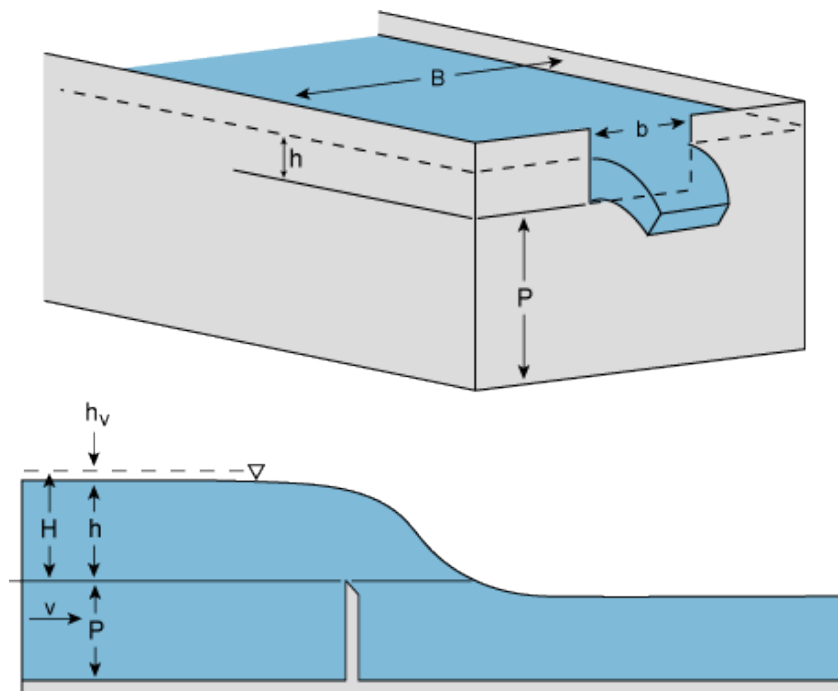

Figure 9.4: A rectangular thin plate weir diagram<sup>92</sup>

- Contracted weirs are constructed where the width of the notch is less than the width of the channel.
- Suppressed weirs have the notch as wide as the width of the channel.
- Broad crested weirs have a flat horizontal surface at the crest ranging from 6" to 15" and are usually made of concrete.
- Sharp crested weirs are made of fiberglass, corrosion resistant metal, or wood.

<sup>91</sup> Image from [Stage-Discharge Relationships](#) is used with permission.

<sup>92</sup> Image from [Stage-Discharge Relationships](#) is used with permission.



V-notch weir angles are commonly 30°, 45°, 60°, and 90°. The larger the angle, the higher volume flows are measured. These types of weirs are always sharp crested design and they measure smaller flows than rectangular weirs. The rate of flow passing over the crest of any type of weir is directly proportional to the depth of water measured from the crest to the water surface. The depth measurement is always made at a distance of at least three times the height upstream of the weir so that the measurement is not affected by the sloping surface of the water approaching the weir. For example, if the weir is 10 feet, then the flow measurement would be collected approximately 30 feet upstream of the weir. The flow depth can be automatically determined and recorded by a float and installed in a device called a stilling well.

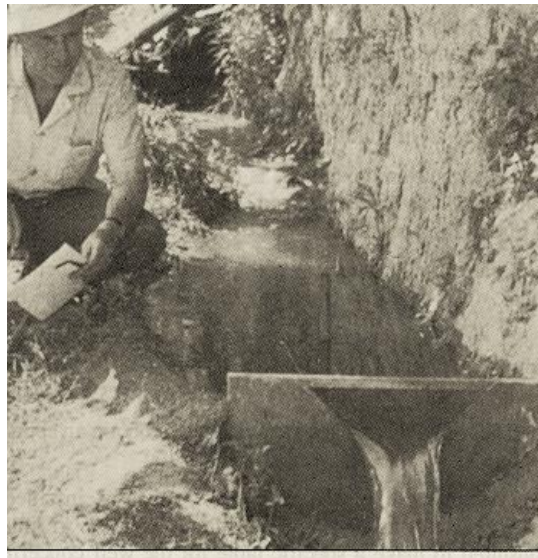

Figure 9.5: A v-notch weir<sup>93</sup>

Flumes are similar to weirs and are also designed to measure the flow in an open-channel section. The principal advantage of a flume is that there are no vertical obstructions as there are in weirs. A flume narrows in the center to increase the velocity of the flow. The velocity through a flume must be high, which also helps keep the flume clean. Flumes are generally more expensive than a weir. The most common type of flume is the Parshall flume. The capacity is determined by the width of the throat of the flume, In Parshall flumes, the widths range from 1 inch to 50 feet. The depth of the flow at a particular point in the flume is directly related to the rate of flow. As with weirs, flume depths can be made by a staff gauge or automatically with a transducer.

---

<sup>93</sup> [Image](#) by the [FAO](#) is licensed under [CC BY-NC-SA 3.0 IGO](#)



Figure 9.6: A flume mechanism<sup>94</sup>

### Compound Meters

At times, both low and high flows need to be measured accurately. As previously discussed, most meters are designed to measure either low or high flows. For example, PD style meters are not good for measuring high flows and turbine style meters are not sufficient at measuring low flows. Installations where both low and high accurate flow measurements are required; a compound meter can be used. **Compound meters** usually consist of a larger turbine meter, a smaller positive displacement meter, and an automatic valve to switch between the two meters. Water passes through the small meter until a certain velocity is reached and then the valve actuates to divert the flow to the larger turbine meter. Two standard meters can also be connected together to provide the same function.



Figure 9.7: A compound meter<sup>95</sup>

<sup>94</sup> Image by the [FAO](#) is licensed under [CC BY-NC-SA 3.0 IGO](#)

<sup>95</sup> Image by [COC Water Systems Technology Faculty](#) is licensed under [CC BY 4.0](#)

## Meter Selecting and Installation

As previously mentioned, meters are often selected based on the volume of water needing to be measured. Meters are commonly one size smaller than the diameter of size of the service lateral. For example, if the service lateral is 1" in diameter serving a residential home, the meter might be  $\frac{3}{4}$ " in size. In a typical residential housing track, it is common to have 1" service laterals and  $\frac{3}{4}$ " meters. However, in commercial areas, the service lateral might be sized for greater usage compared to residential units, but still might have smaller meters. For example, a 2" service lateral might be installed for a bookstore where the only usage might be a single restroom and a  $\frac{3}{4}$ " meter might be installed. However, if this bookstore changes the use to a restaurant and higher flows are required, the service lateral is already sized appropriately and only the meter would need to be replaced with a larger one. Therefore, it is important to size services for future potential uses.

Residential meters are typically  $\frac{5}{8}$ " or  $\frac{3}{4}$ " in size depending on water demand. However, in some communities, residential homes might require internal fire sprinkler systems, in which case the meter size might need to be larger. There are various plumbing codes for sizing meter services and can also be dependent on the number of internal plumbing fixtures. Commercial businesses and multi-family residential homes commonly have meter sizes of 1", 1  $\frac{1}{2}$ ", and 2". If accuracy at low rates is not important and if typical flow rates between 5 % and 35% of the maximum rated capacity, then a positive displacement style of meter is adequate. If accuracy of low flows is required, as well as being able to accurately measure higher flows, then a compound meter should be used. If installations require large capacity and low flow accuracy and flows at 10% to 15% maximum rating, then a turbine meter should be selected.



Figure 9.8: A meter box<sup>96</sup>

<sup>96</sup> Image by [COC Water Systems Technology Faculty](#) is licensed under [CC BY 4.0](#)

Meters are generally installed in concrete or polymer boxes located in the parkway, between the curb and the sidewalk. In very cold climates, meters are installed in deep meter pits or inside buildings. Larger meters are usually installed in precast concrete vaults. Whenever possible, meters should be installed in areas protected against flooding. They should be installed with an upstream and downstream shutoff valve. A meter, angle, or curb stop is the shutoff valve on the upstream side of the meter and there is usually a small gate, globe, or ball valve on the customer (downstream) side of the meter. Meters need to be accessible for maintenance, inspection, and reading and should be protected from freezing. Whenever a utility operator visits a meter, the condition of the meter box and lid should also be checked to make sure there is not a public hazard and that they are in good condition. Registers should be sealed and should have a means of preventing tampering. Depending on the type of usage, meters can also be installed with a bypass. If service cannot be interrupted, a bypass allows for water service to be maintained while the meter is removed or repaired. Some meter installations can have multiple meters installed in series. This type of setup is a manifold installation. They are used when high flows are required and flow cannot be interrupted. One meter at a time can be removed or repaired without disrupting service.



Figure 9.9: A water meter<sup>97</sup>



Figure 9.10: A flanged water meter<sup>98</sup>

Meters up to one inch in size usually have threaded connections each side of the meter. Larger meters tend to have flanged connections. Sometimes a yoke can be used to simplify meter installations in hard to reach areas. Yokes hold the stub ends of the pipe in proper alignment

<sup>97</sup> Image by [Utilitysupplies](#) is licensed under [CC BY-SA 3.0](#)

<sup>98</sup> Image by [COC Water Systems Technology Faculty](#) is licensed under [CC BY 4.0](#)

and spacing to support the meter. Yokes also provide a cushion against stress and strain in the pipe. The image below shows a typical yoke.



*Figure 9.11: A yoke<sup>99</sup>*

As previously mentioned, meter boxes are usually installed on public property, but close to the property line. They should be installed in areas to protect against damage from vehicles. If a meter must be installed in a driveway, steel lids are usually sufficient to help protect the meter from vehicles. Meter couplings or flanges should be located where they are accessible and the dimensions of the meter box or vault should be adequate in size and specified prior to installation. If the meter is installed in a building, then a special valve needs to be installed on the upstream side of the service line. A curb box in either an arch-style or Minneapolis style is used in these situations. An arch-style curb box fits loosely over the top of the stop valve. These installations are adequate if the soil is firm enough. If the surrounding soil is loose, it may work its way into the box or the box may shift making access to the stop valve difficult. The Minneapolis style curb box has threads at the bottom and screws onto special threads on the top of the meter. These installations do not have the issue of shifting or dirt entering the box, but if there is damage to the curb box, damage to the meter and service line can occur.

## Meter Reading

Meter accuracy is important in order to adequately bill for the amount of water actually used. As flow passes through the body of a meter, the volume is transmitted to a register. Old style meters were equipped with circular or round registers. Some gas meters are still this style. The problem with this type of register is the difficulty to read. It is now common to have a register similar to a car odometer. Some are equipped with one or two fixed zeros. The reason for this is because water usage is commonly billed per hundred cubic feet. Therefore, with two fixed

---

<sup>99</sup> Image by [COC Water Systems Technology Faculty](#) is licensed under [CC BY 4.0](#)

zeros, the first number to register on the meter is a one with two trailing fixed zeros, indicating one hundred cubic feet. Some larger meters might have a multiplier of ten of one hundred times. This is because usage is high and it makes it easier to keep track of this large volume of water.

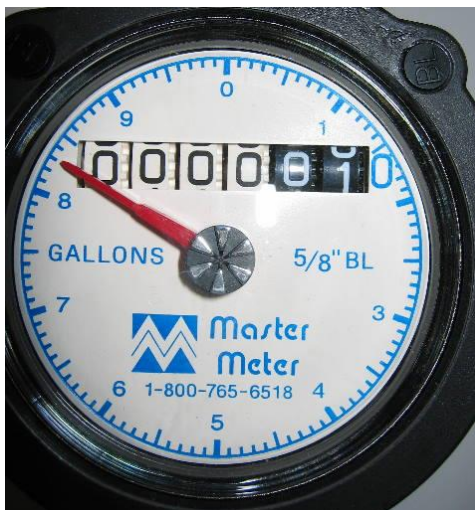

Figure 9.12: A water meter register<sup>100</sup>

There are several ways a meter can be read. The simplest and most common of reading meters is to read them directly. This requires a worker to visit each location where the meter is installed and physically read the register. It requires the meter to be accessible and clean so the register can be read. By visiting meters routinely, workers can see if the meter is being tampered with, damaged, or needs to be replaced. However, this type of reading process can be difficult in cold climates and some customers do not like meter readers visiting their homes. There is also the chance for human error. As technology advances, so do the ways meter reads can be collected. Remote meter reading is becoming more and more common. There are several types of remote meter reading technologies. One remote meter reading technology is referred to as “touch probe” reading. The meter register is connected to touch sensor with a wire. A handheld unit is connected to a probe and is placed on the touch sensor transmitting the meter read. This technology still requires a meter reader to visit each location, but there is less labor involved since the meter box lid does not have to be lifted. Another remote meter reading process is called automatic meter reading (AMR) or “drive-by”. Special electronics are attached to the meter and send out a radio frequency signal. Meter readers’ drive by each location with a computer and a receiving device to pick up the meter reads through the radio frequency signal. The last remote meter reading process is called automatic metering infrastructure (AMI). This type of technology uses radio frequencies with large antennas installed in specific locations or cellular data to transmit meter reads instantly on demand. This type of system requires significant upfront costs, but does not require any labor to read the meters. Some utilities are moving to this type of meter reading technology in order to provide

<sup>100</sup> Image by [Utilitysupplies](#) is licensed under [CC BY-SA 3.0](#)

customers real-time data on their water usage. This can assist utilities with their conservation efforts.

All meters are designed to measure flow velocity where the flow is laminar. If the flow has any turbulence, meters can and will often incorrectly register the meter read. Any kind of pipe bend, valve, obstruction, or change in flow direction can cause turbulence. Therefore, meter manufacturers often specify straight pipe lengths before and after the meter. These distances are typically expressed in pipe diameters. As a rule of thumb, five times the pipe diameter before the meter and two times the diameter after the meter. For example, if the pipe is twelve inches in diameter, there should be sixty (60) inches of straight pipe before the meter and twenty-four inches of straight pipe after the meter.

One of the main reasons a worker should visit a meter regularly is because some customers will attempt to steal water. Some common ways customers attempt to steal water are removing the register, turning the meter backwards, or removing the meter. In addition to visiting a meter routinely, seals can be placed on the meter. Seals do not necessarily prevent pilferage, but if the seal is broken, a worker can quickly identify if the meter has been tampered.

## Meter Testing

Since meter accuracy is important, meters need to be tested to make sure they are operating correctly. Meter manufacturers often include testing results with new meters. In addition, some utilities randomly test new meters to make sure the manufacturer test results are correct. As meters age over time, they can start to under register. Therefore, a routine meter testing program is often recommended. Some utilities randomly remove meters at various ages in order to see if they are still registering properly. Customers can also request for a meter to be tested if they think their meter is not registering correctly. Meters should also be tested after any maintenance.

Some meters (usually larger ones) are testing in place, while smaller meters are typically removed from service and placed on a test bench. Regardless of the location, meters are tested in a similar fashion. A known volume of water is flowed through the meter and the register is compared to this volume. In addition, various flow rates are flowed through the meter, each time comparing the known volume with the volume recorded on the meter register. There are accuracy limits on the different rates of flow that are considered acceptable. Positive displacement meters are tested against a minimum, intermediate, and maximum flow rate, while larger meters might have four or five different flow rates. Below is a set of recommended accuracy limits for different types of meters.

Positive displacement, multi-jet, and turbine meters have an accuracy range of 98.5% to 101.5%. This means if 100 gallons of water are flowed through the meter and the meter registers between 98.5 and 101.5 gallons, then the meter is determined to be accurately measuring flows. The limits for propeller meters are 98% to 102% and compound meters 97% to 103%.

## Key Terms

- **compound meters** – usually consist of a larger turbine meter, a smaller positive displacement meter, and an automatic valve to switch between the two meters
- **magnetic meters** – measure the rate of flow without any moving parts to disrupt the path of the flow
- **multi-jet meters** – use a multiblade, multiport rotor mounted on a vertical spindle within a measuring chamber
- **nutating-disk PD meters** – a measuring chamber containing a flat disk
- **piston PD meters** – operate by the means of a piston, which moves back and forth as the water flows through
- **positive displacement (PD) meters** – commonly used for single-family residential water uses; very accurate in measuring low intermittent flows
- **turbine and propeller meters** – measure the flow of water by means of a rotor
- **velocity meters** – measure the flow through a chamber of specific size and known capacity
- **venturi meter** – consists of an upstream reducer, a short throat piece, and a downstream expansion section. An increase in the flow velocity results in a corresponding pressure drop and the flow rate can be deduced



## Review Questions

1. What types of water meters are used for single family residences? Describe a couple different types.
2. Explain how meter accuracy is important and what is the acceptable accuracy ranges for each class of meters.
3. Explain the importance of meters in a water agency. What are benefits from metering?

## Sample Questions

1. Which of the following meters would be most likely to over-register?
  - a. turbine
  - b. positive displacement
  - c. multi-jet
  - d. all of the above
  
2. When is a compound meter used?
  - a. low flow accuracy is required
  - b. high flow accuracy is required
  - c. constant high velocities at low flows are required
  - d. both a and b
  
3. How do positive displacement meters operate?
  - a. rotor
  - b. nutating disc
  - c. propeller
  - d. electromagnetic waves
  
4. How do meters behave over time?
  - a. over register
  - b. stop
  - c. spontaneously combust
  - d. under register
  
5. Which of the following would not be considered a flow meter?
  - a. weir
  - b. volute
  - c. venturi
  - d. flume

# CHAPTER 10 – WELLS

In this chapter, we will explore groundwater wells.

## OBJECTIVES

After reading this chapter, you should be able to:

- explain how water can be stored underground;
- identify the above ground and below ground components of a well; and
- describe the different methods of drilling wells.

## Groundwater Sources of Supply

Groundwater is one of the most important sources of supply of fresh drinking water throughout the United States. Beneath the earth's surface there are soil formations where water can be extracted in large volumes. These underground soil formations are referred to as aquifers. An aquifer is an underground layer of water bearing permeable rock formations or unconsolidated materials such as sand and gravel.

## Aquifers

There are two main ways water can be stored underground:

- **Unconfined Aquifer** – A natural underground layer of porous, water-bearing (strata) materials (sand, gravel) usually capable of yielding a large amount of supply of water.
- **Confined Aquifer** – A natural underground layer of porous, water-bearing materials (sand, gravel) separated by impermeable layers of materials (clay).

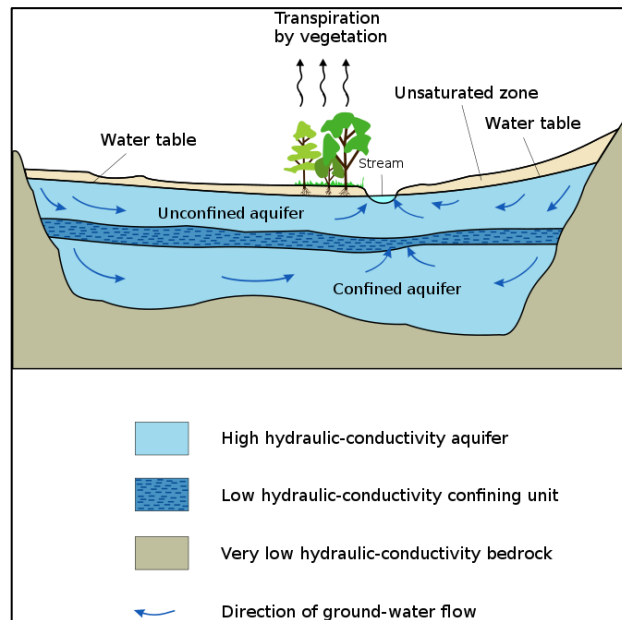

Figure 11.1: An unconfined and confined aquifer<sup>101</sup>

<sup>101</sup> Image by the [USGS](#) is in the public domain

The spaces and fractures in the geologic materials underground store water which can be extracted. This material can be classified as consolidated or unconsolidated. Consolidated aquifer systems are less common and consist of materials such as sandstone, shale, granite, and basalt. The more common underground geologic material contains unconsolidated sediment containing granular material such as sand, gravel, silt, and clay. Alluvium aquifers (sand, gravel, and silt deposits by rivers) are some of the more common unconfined aquifers. Since these aquifer systems generally lie within river beds, they have a direct connection to the ground surface and therefore are more susceptible to contamination. Any contamination deposited on the ground surface has the potential to percolate (“trickle through”) the sediments into the aquifer.



### Pin It! Misconception Alert

Frequently, people will describe an aquifer as an underground swimming pool. While this does illustrate the idea that water is stored underground, it is really misleading. A swimming pool contains water entirely without sediment. An aquifer is mostly sediment or rock with water in the pores between grains of rock or sediment.

## Wells

In order to extract water out of the ground, a well must be drilled. A groundwater well is a structure constructed in the ground through various methods in order to extract or pump water from underground aquifers. They can be as simple as a deep hole with supports to keep the hole from collapsing and the water is withdrawn using a bucket or, they can be thousands of feet deep and constructed with steel reinforcement columns and use pumps to extract the water. Regardless of the type of well, this source is an important resource for communities throughout the world. In this section we will focus on water utility groundwater wells.



Figure 11.2: A groundwater well<sup>102</sup>

<sup>102</sup> Image by [Didieryberghe](#) is in the public domain



Figure 11.3: A hand water pump<sup>103</sup>

There are three main types of groundwater wells. These can be described as:

- **Bored or shallow wells:** These are usually bored into an unconfined water source.
- **Consolidated or rock wells:** These are drilled into a formation consisting entirely of a natural rock formation that contains no soil and does not collapse.
- **Unconsolidated or sand wells:** These are the most common type of drinking water wells and are drilled into a formation of soil, sand, gravel, and clay material. If not supported, these wells will collapse upon themselves.

## Well Components

There are both underground and above ground components to a well. These components channel the water into a pipe, lift the water up from below the ground, and allow the water to flow above ground and into a distribution system. First we will look at the above ground surface features of a well, these are:

- Well casing vent
- Gravel tube
- Sounding tube
- Pump pedestal
- Pump motor base
- Sampling taps
- Air release vacuum breaker valve
- Drain line (Discharge to waste)

## Well Casing Vent

When a well is in operation, the water in the well starts to rise in the column pipe of the well. However, there is an air space between the water and where the water is being pumped. This “air” needs to be released from the column pipe. The well casing vent provides this release. It

---

<sup>103</sup> Image by [SuSanA Secretariat](#) is licensed under [CC BY 2.0](#)

prevents vacuum conditions inside a well by admitting air during the *drawdown* period when the well pump is first started and it prevents pressure buildup inside a well casing during by allowing excess air to escape during the well recovery period after the well pump shuts off.

## Gravel Tube

When a well is drilled, a pipe is lowered into the ground. Water enters in to this pipe from the surrounding soil. We want water to enter the well, but we do not want the surrounding soil (sand) to enter the well. Gravel is used as a barrier between the surround soil outside of the casing and the water entering the casing. A gravel tube is installed to monitor the level of gravel within the well and to add additional gravel as necessary.

## Sounding Tube

A sounding tube is a tube (pipe) that is installed into the well casing to allow for the measurement of groundwater levels within a well. There are several methods of measuring the depth to groundwater, which include automatic measuring devices and manual methods. The simplest means of measuring the level of groundwater below ground surface (bgs) is with a cable lowered into a sounding tube, which has markings identifying distances in various increments (inches.) The cable is connected to a light or signal and when the bottom of the cable touches the water a sound or light signal will occur. Other means of measuring the depth to groundwater include electronic transducers and airline water level measuring. Airline tube measuring is accomplished by lowering a tube in to the well, supplying air pressure to the tube and measuring the pressure with a gauge. Each pounds per square inch of pressure equates to 2.31 feet. In addition to measuring groundwater levels, sounding tubes can be used to add chlorine or other disinfecting or treatment chemical agents in to a well.

## Pump Pedestal

The well casing vent, gravel tube, and sounding tube are encased within a concrete pump pedestal. A pump pedestal is designed to support the entire weight of the pumping unit. The concrete should be continuously poured with steel reinforcement in order to minimize cracks and breaches in the concrete. Fractures in the concrete could expose the inside of the well to surface water and other potential contaminants. A pump pedestal must also be a minimum of 18 inches above the finished elevations of the well pad.

## Pump Motor Base

At the point where the motor rests on the pedestal, it must have a watertight seal. This seal is commonly provided by a neoprene rubber gasket. This establishes a barrier seal between the motor base and the concrete pump pedestal.

## Sampling Taps

### Drain Line (Discharge to waste)

These are only some of the more common above ground components of a well. There are other features, but they will not be covered in this text. The following items are a list of some below ground features of a well.

## Casing

A casing is an impervious durable pipe placed in a well to prevent the walls of the surrounding soil from caving in on the well. A casing is also designed to seal off water from draining into a well from specific depths.

## Conductor casing

When a well is drilled the upper portions of the surrounding soil tends to be loose and a conductor casing is used to support the drilling operations. It is a tubular structure between the drilled hole and the inner casing completed in the upper portion of a well.

## Annular seal

Another means to prevent surface water from entering a well is the **annular seal**. An annular or sanitary seal is a cement grout installed between the well casing and the conductor casing, the space between the conductor casing and the borehole, or the space between the well casing and the borehole depending on the well. This seal also protects the well casing or conductor casing against exterior corrosion. Three types of grout are used; neat cement grout, sand-cement grout, and bentonite clay.

## Intake section

Water enters a well through an intake section. This portion of a well is designed to allow water to enter the well casing and prevent the surrounding soil from entering. The following items are general characteristics of a properly designed intake section.

- Non clogging slots/screen
- Resistant to corrosion
- Sufficient collapse strength
- Resistant to encrusting
- Low head loss
- Prevent sand from entering

There are five common types of intake sections of a well. These include:

- Well screens
- Mill-cut slots
- Formed louvers
- Torch-cut/chisel-cut slots
- Mechanical slots

Well screens are generally constructed of stainless steel, monel metal, special nickel alloy, silicon red brass, red brass, special alloy steel, and plastic. They are broken into three main categories which include continuous slots, bar, and wire-wound screens.

Mill-cut slots are commonly made of the same type and diameter as the casing. The openings are machine milled (cut) into the wall of the casing pipe parallel to the axis of the casing and uniformly spaced around the casing pipe.

Formed louvers are machined horizontal to the axis of the casing with the openings facing downward. They are shaped to create an upward flow as the water enters a well and they are placed together in vertical rows.

Torch-cut slots are not very common. They are relatively simple to create, but very difficult to control the size of the openings. This has a tendency to produce excessive quantities of sand. Mechanical slots are usually slotted after the well has been drilled. The openings are made opposite the water-bearing formations by means of a casing perforator tool lowered into the well and activated from the drill rig. One main downside of this process is the openings cannot be closely spaced.

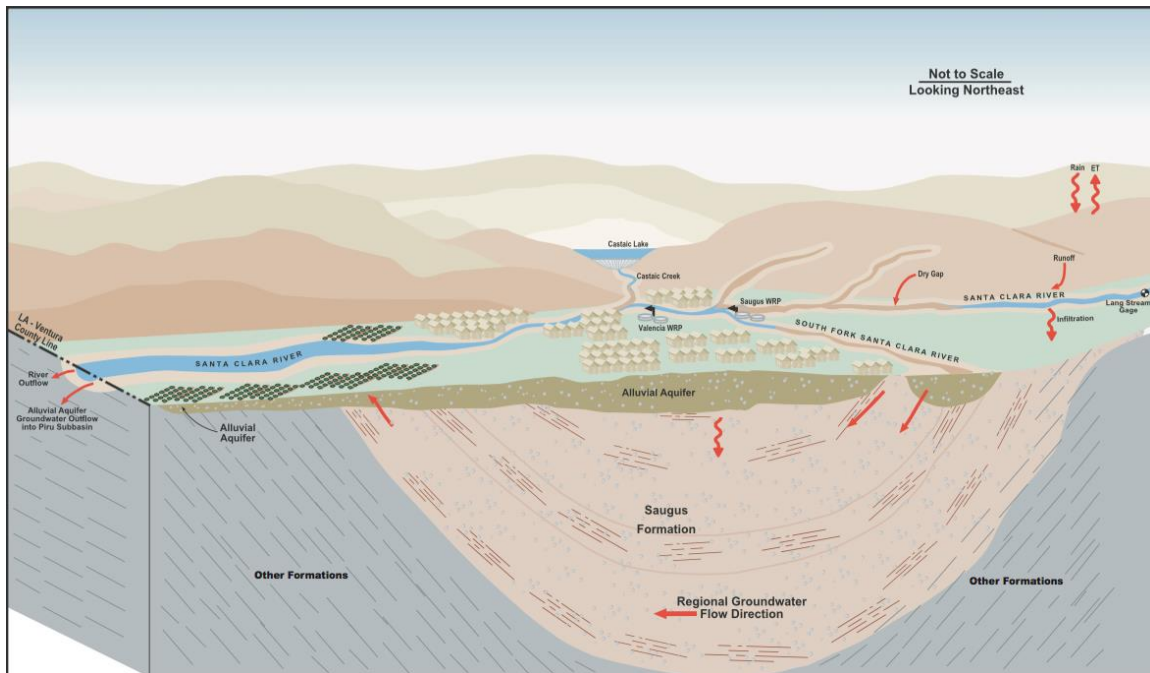

Figure 11.4: Diagram of waterflow<sup>104</sup>

## Well Drilling

In order for water to be extracted from an aquifer, a well must be constructed (drilled). There are several methods of well drilling. The more common methods include:

- Cable Tool
- California Stovepipe
- Direct Rotary
- Reverse Circulation Rotary
- Air Rotary

## Cable Tool Method

The cable tool method of drilling wells is also referred to as the “percussion” method. This method involves the lifting and dropping of a heavy string of drilling tools into the borehole. The cable tools can weigh in excess of one ton and the drill bit breaks or crushes consolidated rock into smaller and smaller fragments. In unconsolidated rock the bit loosens and breaks

<sup>104</sup> Adapted by LACSD from the Task 2A - Conceptual Model Development East and Piru Subbasins Final Report by CH2M HILL 2006.



apart the material. The reciprocating action of the tools mixes the crushed and loosened materials with water to form a slurry at the bottom of the borehole. The slurry needs to be removed and is done so with the use of a sand pump or bailer. The cable tool drilling equipment consists of five components; drill bit, drill stem, drilling jars, swivel socket, and cable.

### California Stovepipe

This method is similar to the cable tool method. The difference is a heavy bailer is used as both a drill bit and bailer. This heavy bailer is referred to as a mud scow. The stovepipe casing is what also distinguishes this method from others. It uses laminated steel in short lengths providing added strength, as opposed to using standard steel. Hydraulics jacks are used to force the casing downward as opposed to driving the casing with impact tools. Once the casing is at the desired depth, a perforator is used to puncture holes in the pipe opposite the water bearing formation.

### Direct Rotary

As drilling technologies progressed, the desire for faster drilling speeds and greater drilling depths increased. The direct rotary drilling method uses a rotating drill bit. The cuttings are removed by the continuous circulation motion of a drilling fluid as the bit penetrates the formation. The bit is attached to a lower end of a string drill pipe, which transmits the rotating action from the rig to the bit. The drilling fluid is pumped down through the drill pipe and out through the ports or jets in the bit. The fluid flows upward in the annular space between the hole and the drill pipe, carrying the cuttings in suspension to the surface.

### Reverse Circulation Rotary

The reverse circulation rotary drilling method was designed to overcome limitations in borehole diameter and drilling depths. In this method, both water and air are used as the drilling fluid and the direction of the drilling rotation is reversed. As a result of this direction, the drilling fluid and the load of cuttings move upward inside the drill pipe and are discharged by the pump into a settling pit.

### Air Rotary

In solid consolidated materials, standard drilling practices are more difficult. Therefore, an air rotary method is often employed. This process uses compressed air as the drilling fluid as opposed to drilling mud. Air is circulated through the center of the drill pipe out through ports in the drill bit. In order to break through consolidated material, pressures from 100 to 250 pounds per square inch (psi) are needed. The process of removing the cuttings requires ascending air velocities of at least 3,000 feet per minute.

### Shallow Wells

In some areas, groundwater levels are very shallow. These are usually in areas adjacent to running riverbeds and lakes. In these areas, the surface river and lake water could be used as drinking supplies. However, surface waters require a significant amount of treatment in order

to remove turbidity (sediment). This can be quite costly. One of the benefits of groundwater is the natural filtration the geological formations provide. In these areas shallow collector wells are often used. Trenches are dug around ten to twenty feet deep and screened pipe is laid horizontally to the river or lake bank. Depending on the type of surrounding soil, these pipes are often radially driven. Caissons (watertight retaining structures) are used to gain access to the bottom of a stream or other water body. A common shallow collector type is a Ranney.

## Well Pumps

A few terms should be defined before discussing the classification and types of pumps used for wells. These terms are general terms relating to the inlet and outlet side of all pumps. Pressure is the concept of a continuous force being exerted on or against an object, while “head” is commonly used because it evaluates a pump’s capacity to do a job. For this discussion, both pressure and head will be considered interchangeable. Pressure is expressed as pounds per square inch (psi) and head expressed in feet.

## Suction Head, Suction Lift, and Discharge Head

The inlet side of a pump is referred to as **suction head** or suction lift. Suction, referring to the “sucking” or pulling aspect of a fluid entering a pump. If the fluid is above the inlet side of a pump it is referred to as suction head. This is because the fluid is providing pressure to the inlet or suction side of a pump. In essence, it is helping the pump push water through the pump and to the discharge side of the pump. If the fluid being pumped is below the suction side, then the pump has to “suck” or lift the water up to the pump. This is referred to as suction lift. **Discharge head** refers to the outlet side of a pump, which is “pushing” the fluid out.

There are two major pump classifications for wells: positive displacement and variable displacement. The common types of each include:

- Piston (positive displacement)
- Rotary (positive displacement)
- Centrifugal (variable displacement)
- Turbine (variable displacement)
- Jet (variable displacement)

Positive displacement well pumps deliver the same volume or flow of water against any head pressure within the operating capacity. Typical types are piston (reciprocating) pumps and screw or squeeze displacement (diaphragm) pumps.

Variable displacement well pumps deliver water with the volume or flow varying inversely with the head (the greater the head, the less the volume or flow) against which they are operating. The major types are centrifugal, jet, and airlift pumps.

There are various uses for each type of pump throughout the water utility industry. However, turbine pumps are predominately used for groundwater wells. Since groundwater is found at different depths below the ground, it only stands to reason there might be different types of “turbine” pumps to lift this water out of the ground.

- **Shallow Well Pumps** –Shallow can be a relative term, but in this context let’s assume it is within fifty feet below ground surface. Under these circumstances a shallow well pump would be installed above a well. It would take water from the well by suction lift. The critical issue is the water level must be within the “lift” capacity of the pump
- **Deep Well Pumps** – Since many wells are drilled deeper than fifty feet, most pumps cannot “lift” the water above these depths when they are installed above a well. Therefore, deep well pumps are used. These types of turbine pumps have a series of pump bowls installed in a well with the inlet (suction) section of the pump submerged below the pumping level in a well.

Since pressures can be expressed in both units of psi and feet, there needs to be a way to convert between the two. One pound per square inch equates to just over two feet. See the example below.

1 psi = 2.31 feet (head)

If a pump has a discharge head of 100 psi, how many feet does this equal?

$$\frac{100 \text{ psi}}{1} \times \frac{2.31 \text{ feet}}{1 \text{ psi}} = 231 \text{ feet}$$

While this text discusses aspects of water related mathematical computations, it is advised to take specific coursework in waterworks mathematics.

### Measuring Groundwater Levels

An important set of data associated with groundwater wells is the measurement of water below ground surface. There are two common measurements in a groundwater well: static and pumping. The **static water level** within a well is the depth of water below ground surface when a well is not running. In contrast, the **pumping level** is the measure below ground surface when a well is running. The diagram below illustrates these two terms.

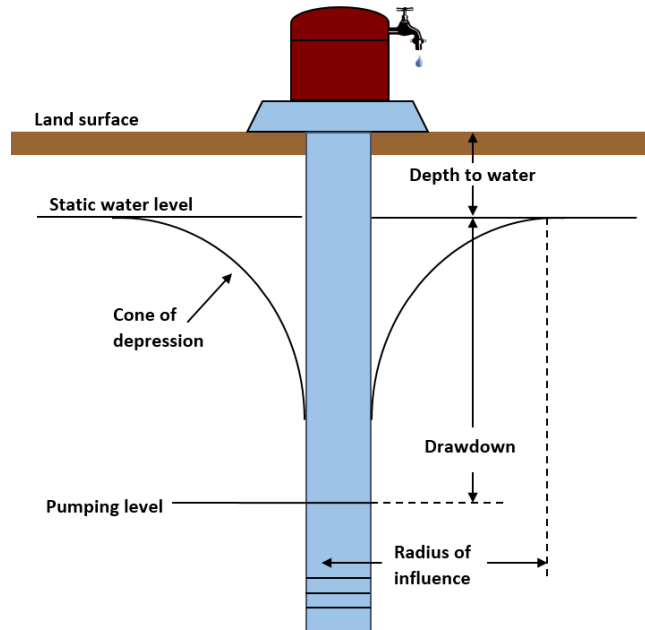

Figure 11.5: This diagram demonstrates how groundwater is measured through static and pumping levels<sup>105</sup>

In this diagram, there are several other important terms. **Drawdown** is the difference between the pumping and static water levels. This level identifies the distance the water level drops when a well is off and when it is running. Also depicted in the diagram is something referred to as **cone of depression**. The water level in an aquifer is only affected by a well running within a certain area around the well. This area of “depression” pulls the water down deeper closer to the well and the further away from the well the affect is less. Hence, a “cone” shaped affect occurs. The distance from the center of a well to the farthest area where the depression effect occurs is referred to as the **radius of influence**. These measurements help in the analysis of the health of the underlying aquifer and the efficiency of a well.

### Key Terms

- **bored or shallow wells** – wells that are usually bored into an unconfined water source.
- **cone of depression** – an area around the well affected by pumping
- **confined aquifer** – a natural underground layer of porous, water-bearing materials (sand, gravel) separated by impermeable layers of materials (clay).
- **consolidated or rock wells** – wells that are drilled into a formation consisting entirely of a natural rock formation that contains no soil and does not collapse
- **discharge head** – the pressure on the outlet side of a pump
- **drawdown** – difference between pumping and static water levels
- **pumping level** – within a well, is the measure below ground surface when a well is running
- **radius of influence** – the distance from the center of the well to the farthest area where the depression effect occurs

<sup>105</sup> Image by [COC OER](#) is licensed under [CC BY 4.0](#)

- **static water level** – within a well, the static water level is the depth of water below ground surface when a well is not running
- **suction head** – the pressure on the inlet side of a pump; also known as suction lift
- **unconfined aquifer** – a natural underground layer of porous, water-bearing (strata) materials (sand, gravel) usually capable of yielding a large amount of water.
- **unconsolidated or sand wells** – wells that are the most common type of drinking water wells and are drilled into a formation of soil, sand, gravel, and clay material; if not supported, these wells will collapse upon themselves

## Review Questions

1. Why is a well casing vent necessary?
2. As an operator, how would you collect groundwater levels? What would you measure?
3. Why do you think so much emphasis is placed on a sanitary seal and a watertight seal in the pump motor base?

## Sample Questions

1. If an airline measuring device used to measure the depth to groundwater displays a pressure of 125 psi, what is the depth in feet?
  - a. 125 feet
  - b. 289 feet
  - c. 54 feet
  - d. None of the above
2. What describes an unconfined aquifer?
  - a. more susceptible to contamination than a confined aquifer
  - b. less susceptible to contamination than a confined aquifer
  - c. typically deep within the earth's crust
  - d. not a common source of water for a water utility
3. How is a sounding tube used?
  - a. to hear if a motor is running correctly
  - b. to test the flow of a well
  - c. to measure the depth to groundwater within a well
  - d. to see if a well works properly
4. Which of the following materials is not a common well screen?
  - a. stainless steel
  - b. iron
  - c. Monel metal
  - d. special nickel alloy
5. What is the annular seal commonly made of?
  - a. plastic
  - b. steel
  - c. bentonite clay
  - d. all of the above

# GLOSSARY

- **Action Level (AL)** – action Levels are set for certain contaminants where an MCL does not exist and some type of response (action) is required by the water utility if an AL is exceeded
- **adhesion** – the physical property caused by attraction of molecules that allows water to “stick” to the glass when you fill a glass with water; the meniscus is evidence of adhesion
- **appurtenances** – accessories in a functioning distribution system
- **arterial loop system** – a system that provides flexibility by supplying water to the distribution system from multiple locations; surrounding the distribution system with larger diameter water mains
- **asbestos-cement pipe (ACP)** – pipe that was first introduced in the US around 1930; was commonly used in areas where metallic pipe was subject to corrosion
- **Average Day Demand (ADD)** – the total distribution system water use over one year, which is then divided by 365 days. In the design of a new distribution system without any existing users, land use projections are commonly used to estimate the amount of water, which will be used by future users
- **axial flow** – in-line pumps that work on a vertical plane in relation to the water; axial flow pumps offer very high flow rates and very low amounts of pressure head
- **ball valve** – a type of valve with a 90 degree rotation between open and closed position, low flow resistance and suitable for throttling flow
- **bonnet** – the top section of a hydrant
- **bored or shallow wells** – wells that are usually bored into an unconfined water source.
- **butterfly valve** – a valve that rotates with a disc similar to a gate valve, but this disc rotates on a shaft to open and close; easier to operate than a gate valve because as they open, the force of the water pushes against the opposite side of the disc helping to open the valve
- **cavitate** – rumbling, popping, crackling noise that occurs at high pressure
- **centrifugal pumps** – some of the most common types of pumps used in the water industry; they convert rotational kinetic energy to hydrodynamic energy
- **check valve** – a valve that allows flows in only one direction and therefore has very specific applications
- **closed impellers** – generally pump finished treated waters and provide a controlled area to channel water through the impeller.
- **cohesion** – the ability of water to be attracted to other water molecules that allows insects to seemingly walk on water
- **compound meters** – usually consist of a larger turbine meter, a smaller positive displacement meter, and an automatic valve to switch between the two meters
- **cone of depression** – an area around the well affected by pumping
- **cone valve** – a type of rotary valve that is good for controlling flow and providing low flow resistance



- **confined aquifer** – a natural underground layer of porous, water-bearing materials (sand, gravel) separated by impermeable layers of materials (clay).
- **confined aquifer** – an aquifer of sand and gravel with an overlying and underlying impervious rock or clay layer
- **consolidated or rock wells** – wells that are drilled into a formation consisting entirely of a natural rock formation that contains no soil and does not collapse
- **Consumer Confidence Report (CCR)** – an annual report sent to all customers receiving water from a utility
- **corporation (corp) stop** – the valve that connects a distribution main to a service lateral
- **curb stop** – the valve that connects the service lateral to a meter
- **Department of Drinking Water (DDW)** – state division within the State Water Resources Control Board that regulates public water systems and is broken into three branches, the Southern California Field Operation Branch, the Northern California Field Operation Branch, and the Program Management Branch
- **Detection Limit for Reporting (DLR)** – the Detection Limit for Reporting is set at a level that laboratories can accurately reproduce with the current method of analysis.
- **diffuser casing** – has many vanes in order to build pressure at the point where the edge of the casing approaches the edge of the impeller. Diffuser designs are generally more compact compared to volute designs.
- **discharge head** – the pressure on the outlet side of a pump
- **double check (DC) valve devices** – similar to RP devices, except they do not have a relief valve in the center
- **drawdown** – difference between pumping and static water levels
- **dry-top dry barrel hydrant** – a hydrant that has the threaded end of the stem sealed off from water in the barrel when the hydrant is filled with water and in use
- **Environmental Protection Agency (EPA)** – federal agency that oversees federal drinking water quality standards
- **evapotranspiration** – the process of water transferring from the land to the atmosphere from the soil and other surfaces and from transpiration from the plants
- **flanged connection** - provides a strong and ridged connection and allows for easy disassembly if a section of pipe or other appurtenance needs to be removed; not as common in underground installations, primarily because of the exposed nuts and bolts of flanged fittings
- **flexural strength** – the ability of a pipe to bend or flex without breaking
- **float on the system** – a method of operating a storage facility where daily flow into the system is approximately equal to average day demand; when customer demands are low, the storage facility will fill and when demands are high, the storage facility will empty
- **fractured bedrock** – where the water is stored in complex fractures (cracks) within the rock formation
- **grey cast-iron pipe (CIP)** – pipe that is strong and provided a long service life as well as easier to manufacture; one of the main drawbacks to this pipe was its brittleness

- **grid system** - one of the more desirable distribution system layouts; provides water to all customers from multiple areas
- **Hazen-Williams equation or C-factor** - a standard calculation used by engineers to determine this head loss due to friction
- **hydrologic cycle** – continuous movement of water throughout the earth
- **infiltration** – the process of water entering the ground surface
- **magnetic meters** – measure the rate of flow without any moving parts to disrupt the path of the flow
- **Maximum Contaminant Level (MCL)** – levels set as close to the MCLG as feasible
- **Maximum Contaminant Level Goal (MCLG)** – levels set at which no known or anticipated adverse health effects would occur
- **Maximum Day Demand (MDD)** – determined by looking at the entire demand over one year and determining the day with the highest (maximum) usage over one twenty-four hour period
- **mechanical joints** – a restrained type of pipe fitting (joint), which still allows for some longitudinal and latitudinal (side to side) movement (deflection) between pipes. Flanged connections are also used to connect pipes and fittings together
- **mixed flow** – a cross between an axial flow and radial flow pump; the impeller sits within the pipe and turns, but the turning mechanism is essentially diagonal; centrifugal force moves the water while accelerating from the axial direction for the impeller
- **multi-jet meters** – use a multiblade, multiport rotor mounted on a vertical spindle within a measuring chamber
- **nutating-disk PD meters** – a measuring chamber containing a flat disk
- **open impellers** – generally used to pump raw water; used because raw water may carry with it some solids, which would damage the other impeller designs
- **Peak Hour Demand (PHD)** – the highest water usage over a one hour period
- **percolation** – the process of water moving from shallow to deep
- **pigging** – the process to clean the inside of a water main
- **piston PD meters** – operate by the means of a piston, which moves back and forth as the water flows through
- **plug valves** – a type of rotary valve that can be used to throttle and control flow
- **polyvinyl chloride pipe** – pipe first introduced around 1940; the durability, resistance to corrosion, lightweight, and cost effectiveness soon became very attractive in the waterworks industry
- **positive displacement (PD) meters** – commonly used for single-family residential water uses; very accurate in measuring low intermittent flows
- **positive displacement pumps** – pumps that “displace” liquid by mechanical action providing constant flow at a fixed speed, despite changes in pressure; move fluids by trapping a fixed amount and displacing (moving) the trapped volume into a vessel such as a pipe
- **Public Health Goals (PHG)** – Public Health Goals are similar to MCLGs; California non-enforceable standards where an MCL does not exist

- **pumping level** – within a well, is the measure below ground surface when a well is running
- **push-on joints** – connections manufactured in a “bell” and “spigot” style
- **radial flow** – a centrifugal pump that discharges the fluid radially (at right angles to the pump shaft); radial flow means the pump operates on a horizontal plane to the direction of flow
- **radius of influence** – the distance from the center of the well to the farthest area where the depression effect occurs
- **recycled water** – treated wastewater (through tertiary treatment) that can be used for irrigation and non-potable uses
- **reduced pressure principal (RP) backflow device** – consists of two spring-loaded check valves with a pressure-regulated relief valve between the two valves
- **restrained joint** - a type of pipe fitting (joint), which uses lugs, bolts, and gaskets to prevent longitudinal (back and forth) movement between pipes
- **semi-open impellers** – can pump liquids with some solids, but not as much as the open design
- **State Water Resources Control Board (SWRCB)** – state agency that is responsible for drinking water standards as the Regional Water Quality Control Boards (RWQCB) and functions as the regulatory authority for surface water quality and surface water rights
- **static water level** - within a well, the static water level is the depth of water below ground surface when a well is not running
- **sublimation** – the process through which a substance passes from a solid to a gas (without being a liquid)
- **suction head** – the pressure on the inlet side of a pump; also known as suction lift
- **tensile strength** – the measure of the resistance a pipe has to the longitudinal or lengthwise pull it has before it will fail
- **transpiration** – the evaporation from plant leaves
- **tree system** - the least desirable design typically fed by one larger main and then branches off to smaller distribution mains
- **turbine** – a type of centrifugal pump most commonly used in well pump operations
- **turbine and propeller meters** – measure the flow of water by means of a rotor
- **unconfined aquifer** – a natural underground layer of porous, water-bearing (strata) materials (sand, gravel) usually capable of yielding a large amount of water.
- **unconfined aquifer** – an aquifer that has the upper surface open to the atmosphere through permeable material such as sand and gravel
- **unconsolidated or sand wells** – wells that are the most common type of drinking water wells and are drilled into a formation of soil, sand, gravel, and clay material; if not supported, these wells will collapse upon themselves
- **variable displacement pumps** – pumps that deliver the same volume or flow of water against any head pressure within the operating capacity; most common in the water industry are turbine and centrifugal
- **velocity meters** – measure the flow through a chamber of specific size and known capacity

- **venturi meter** – consists of an upstream reducer, a short throat piece, and a downstream expansion section. An increase in the flow velocity results in a corresponding pressure drop and the flow rate can be deduced
- **volute casing** – casing designed to utilize the incoming velocity of the liquid entering the impeller and converting this velocity into pressure
- **wet-top dry barrel hydrant** – a hydrant that is constructed such that the threaded end of the stem and the operating nut are sealed from water when the valve is open
- **wooden water mains** – pipe that is hollowed out wooden logs did not expand like metal pipes and the thickness provided insulation properties